

BSES YAMUNA POWER LTD (BYPL)

Notice Inviting Tender (NIT)

for

**“Electrification of East Delhi Hub, Karkardooma near karkardooma
Metro Station Scheme no. JM22EL2013”**

NIT No.: CMC/BY/22-23/RS/SvS/AS/66

Dated: 22.02.2023

Due Date for Submission of Tender: 14.03.2023, 15:00 HRS

Date and Time of opening: 15.03.2023, 15:30 HRS

BSES YAMUNA POWER LIMITED,

Shakti Kiran Building, Karkardooma, New Delhi – 110032

Corporate Identification Number: U40109DL2001PLC111525

Website : www.bsedelhi.com

(This document is meant for the exclusive purpose of bidding against this NIT Number /Specification and shall not be transferred, reproduced, or otherwise used for purposes other than that for which it is specifically issued).

CONTENTS

S.No.	ITEM	DISCRIPTION
1	CHECK LIST	CHECK LIST FOR BID SUBMISSION
2	SECTIONS	
2.1	SECTION-I	REQUEST FOR QUOTATION (RFQ)
2.2	SECTION-II	INSTRUCTION TO BIDDERS (ITB)
2.3	SECTION-III	SPECIAL CONDITIONS OF CONTRACT (SCC)
2.4	SECTION-IV	GENERAL CONDITIONS OF CONTRACT (GCC)
2.5	SECTION-V	SCOPE OF WORK
2.5	SECTION-VI	NA
2.6	SECTION-VII	PRICE BID
3	ANNEXURES	
3.1	ANNEXURE-I	BID FORM
3.2	ANNEXURE-II	BIDDER'S DETAILS
3.3	ANNEXURE-III	ACCEPTANCE OF REVERSE AUCTION
3.4	ANNEXURE-IV	ENVIRONMENTAL, OCCUPATIONAL HEALTH & SAFETY CONDITIONS OF CONTRACT
4	FORMATS	
4.1	EMD	EARNEST MONEY DEPOSIT (EMD) BANK GUARANTEE
4.2	CPBG	CONTRACT CUM PERFORMANCE BANK GUARANTEE (CPBG)
4.3	NDA	NON-DISCLOSURE AGREEMENT (NDA)
4.4	NDD	NO DEVIATION DECLARATION (NDD)
4.5	COMMUNICATION	BIDDER'S COMMUNICATION DETAILS

INDEX

SECTION- I REQUEST FOR QUOTATION (RFQ)	8
1. GENERAL.....	9
2. POINTS TO BE NOTED.....	10
3. EMD.....	10
4. QUALIFYING REQUIREMENTS (QR)	11
4.1 TECHNICAL QR:	11
4.2 FINANCIAL QR:	11
4.3 OTHER REQUIREMENTS:	12
5. PRE-BID MEETING:.....	13
6. BID SUBMISSION.....	14
7. TIME SCHEDULE	15
8. AWARD DECISION	16
9. MARKET INTEGRITY.....	16
10. CONFIDENTIALITY.....	17
11. CONTACT INFORMATION.....	17
SECTION-II : INSTRUCTIONS TO BIDDERS (ITB)	18
1. GENERAL.....	19
2. SCOPE OF WORK	19
3. DISCLAIMER	19
4. COST OF BIDDING.....	20
5. TENDER DOCUMENTS	21
6. AMENDMENT OF TENDER DOCUMENTS.....	21
7. PREPARATION OF BIDS & LANGUAGE.....	21
8. DOCUMENTS COMPRISING THE BID	21
9. BID FORM.....	22
10. BID PRICES.....	22
11. BID CURRENCIES	22
12. PERIOD OF VALIDITY OF BIDS.....	22
13. ALTERNATIVE BIDS.....	22
14. FORMAT AND SIGNING OF BID.....	22
15. SEALING AND MARKING OF BIDS.....	23

16.	DEADLINE FOR SUBMISSION OF BIDS.....	23
17.	ONE BID PER BIDDER.....	23
18.	LATE BIDS	23
19.	MODIFICATIONS AND WITHDRAWAL OF BIDS.....	23
20.	EVALUATION OF BID	23
21.	CLARIFICATION OF BIDS	23
22.	PRELIMINARY EXAMINATION OF BIDS / RESPONSIVENESS.....	24
23.	EVALUATION AND COMPARISON OF BIDS	24
24.	CONTACTING THE COMPANY	25
25.	COMPANY 'S RIGHT TO ACCEPT ANY BID AND TO REJECT ANY OR ALL BIDS	25
26.	AWARD OF CONTRACT	25
27.	THE COMPANY'S RIGHT TO VARY QUANTITIES	25
28.	LETTER OF INTENT/ NOTIFICATION OF AWARD	25
29.	CORRUPT OR FRAUDULENT PRACTICES.....	26
30.	PROCESS TO BE CONFIDENTIAL.....	26
	SECTION – III : SPECIAL CONDITIONS OF CONTRACT (SCC)	27
1.	DEFINITIONS	28
	ENGINEER IN-CHARGE (EIC) / OFFICER-IN-CHARGE (OIC)	28
2.	SCOPE OF WORK	28
3.	EFFECTIVE DATE, TIME AND VALIDITY.....	28
4.	ORDER VALUE	29
5.	RATES & ESCALATION	29
6.	CONTRACT CUM PERFORMANCE SECURITY BANK GUARANTEE (CPBG)	29
7.	PAYMENT TERMS:.....	30
8.	LIQUIDATED DAMAGES & PENALTY	31
9.	DERC GUIDELINES & REGULATIONS	31
10.	INSURANCE POLICIES.....	32
11.	WARRANTY / DEFECT LIABILITY PERIOD.....	32
	SECTION – IV : GENERAL CONDITIONS OF CONTRACT (GCC)	34
1.	DEFINITION & INTERPRETATION	35
2.	PRIORITY OF CONTRACT DOCUMENTS.....	39
3.	AMENDMENT	39
4.	LANGUAGE AND MEASUREMENT.....	40
5.	EXAMINATION OF SITE & LOCAL CONDITIONS	40
6.	TAXES & DUTIES.....	40

7.	PAYMENT	41
8.	TAX INVOICE SUBMISSION PROCEDURE AND CERTIFICATION	42
9.	TIME ESSENCE OF CONTRACT	42
10.	LIQUIDATED DAMAGE	42
11.	NOT USED	43
12.	OPENING OF SITE OFFICE:.....	43
13.	ACCESS TO THE SITE	43
14.	INSPECTION & QUALITY CONTROL.....	43
15.	DEMOBILISATION/ HANDOVER ON CONTRACT COMPLETION.....	44
16.	REPORTS AND INFORMATION.....	44
17.	STATUTORY OBLIGATIONS	45
18.	PENALTY FOR NON-COMPLIANCE OF STATUTORY REGULATIONS	46
19.	PENALTY FOR MISCONDUCT/FAILURE IN PERFORMANCE OF TASK UNDER AGREEMENT	46
20.	STATUTORY PERMISSION/ APPROVALS.....	48
21.	PERMITS, LICENSES&APPROVALS.....	49
22.	REPRESENTATION, WARRANTIES AND GUARANTEES.....	50
23.	EVENTS OF DEFAULTS	50
24.	RISK & COST	51
25.	LIMITATION OF LIABILITY	51
26.	TERMINATION	51
27.	GOVERNING LAW AND ARBITRATION.....	52
28.	FORCE MAJEURE	53
29.	NOTICE & COMMUNICATION	55
30.	SAFETY CODE	55
31.	WORKMEN COMPENSATION.....	56
32.	THIRD PARTY INSURANCE	56
33.	HUMAN RESOURCE ISSUES	56
34.	DEPLOYMENT OF RESOURCES.....	58
35.	REPLACEMENT OF RESOURCE(S).....	59
36.	CONTRACTOR'S OBLIGATIONS.....	59
37.	THE COMPANY/BYPL'S OBLIGATIONS/RESPONSIBILITIES	64
38.	INDEMNITY.....	65
39.	SECRECY & CONFIDENTIALITY	65
40.	NON-EXCLUSIVITY	66
41.	SEVERABILITY	66

42.	ASSIGNMENT& SUBLETTING	66
43.	ASSIGNMENT BY THE COMPANY	66
44.	NOT USED	66
45.	NO JOINT VENTURE.....	67
46.	WAIVER OF RIGHTS.....	67
47.	THE COMPANY'S RIGHT TO VARY QUANTITIES.....	67
48.	CONTRACTOR'S EQUIPMENT	67
49.	AVAILABILITY OF TOOL &PLANT (T&P).....	67
50.	FREE ISSUE MATERIAL.....	68
51.	VENDOR CODE OF CONDUCT	68
52.	DISCLOSURE OF RELATIONSHIP	68
53.	MSME.....	68
54.	COVID GUIDELINES.....	69
55.	CLEANLINESS & PRECAUTIONS TO BE TAKEN WHILE DOING WORK AT SITE TO PREVENT DUST POLLUTION.....	69
56.	ENVIRONMENTAL, HEALTH &SAFETY.....	70
57.	ACCEPTANCE	71
	SECTION – V : SCOPE OF WORK	72
	SECTION – VII: PRICE BID	79
	ANNEXURE –I : BID FORM	88
	ANNEXURE – II : BIDDER'S DETAILS.....	89
	ANNEXURE – III.....	92
	ACCEPTANCE FORM FOR PARTICIPATION IN REVERSE AUCTION EVENT	92
	ANNEXURE – IV:.....	94
	ENVIRONMENTAL, OCCUPATIONAL HEALTH & SAFETY CONDITIONS OF CONTRACT	94

CHECK LIST**(FOR BID SUBMISSION)**

S. No	Item Description	Y/N
1	BID INDEX	
2	COVERING LETTER	
3	TENDER FEE	
4	EARNEST MONEY DEPOSIT	
5	POWER OF ATTORNEY	
6	BID FORM DULY SIGNED	
7	NON-DISCLOSURE AGREEMENT (NDA)	
8	NO DEVIATION DECLARATION (NDD)	
9	UNPRICED TECHNO-COMMERCIAL BID (IN SEPARATE SEALED ENVELOPE-1)	
10	PRICE BID (IN SEPARATE SEALED ENVELOPE-2)	
11	COMPLETE BID DOCUMENTS, ENVELOPE 1 & 2 (IN SEPARATE SEALED ENVELOPE-3)	

SECTION- I REQUEST FOR QUOTATION (RFQ)

SECTION- I REQUEST FOR QUOTATION (RFQ)

1. GENERAL

BSES Yamuna Power Limited invites sealed tenders on a “Single Stage: Two Envelope” bidding basis (Envelope –I, Techno-Commercial Bid & Envelope-II, Price Bid) from eligible Bidders for “Electrification of East Delhi Hub, Karkardooma near Karkardooma Metro Station Scheme no. JM22EL2013”.

1.1. The bidder must qualify the requirements as specified in heading “Qualifying Requirements” of this RFQ.

1.2. The sealed envelopes shall be duly super-scribed as:

“NIT No.: CMC/BY/22-23/RS/SvS/AS/66 Dated: 22.02.2023”

for

“Electrification of East Delhi Hub, Karkardooma near Karkardooma Metro Station Scheme no. JM22EL2013”

1.3. Schedule of the tendering process is given below. Detailed Specification, Scope of Work, Terms & Conditions, etc are mentioned in the Tender documents, which is available on our website.

Cost of Tender Documents (Non- Refundable)	Rs. 1180/- (including GST)
Earnest money Deposit	Rs 3 Lakh
Duration of the Work	6 Months
Tender documents on sale	22/02/2023 to 14/03/2023 (Working days)
Date & time of Submission of Bid	14/03/2023 till 15:00 HRS
Date & time of opening of Techno-Commercial Bid	15/03/2023 at 15:30 HRS

1.4. The tender document can be obtained from address given below against submission of non-refundable demand draft of **Rs. 1180/-** drawn in favour of BSES Yamuna Power Ltd, payable at Delhi:

Head of Department
Contracts & Material Dept.
BSES Yamuna Power Limited
IIIrd Floor, “A” Block, Shakti Kiran Building
Karkardooma, New Delhi -110032

1.5. Only DD shall be accepted for tender fees.

1.6. The tender documents will be issued on all working days up to the date mentioned in clause 1.3. The tender documents & detail terms and conditions can also be downloaded from the website www.bsedelhi.com. In case tender documents are downloaded from

the above website, then the bidder has to enclose a separate demand draft covering the cost of bid documents.

2. POINTS TO BE NOTED

- 2.1. Works envisaged under this contract are required to be executed in all respects up to the period of completion/ duration of work mentioned above.
- 2.2. Only those agencies, who fulfil the qualifying criteria as mentioned in clause 3 should submit the tender documents.
- 2.3. BSES YAMUNA Power Ltd reserves the right to accept/reject any or all bids without assigning any reason thereof and alter/amend/modify/add/reduce the amount and quantity mentioned in the tender documents at the time of placing Order
- 2.4. The bid will be summarily rejected if:
 - (a) **Earnest Money Deposit (EMD) and Tender Fee** of requisite amount is not deposited as per tender conditions
 - (b) Bid received after due date and time.

3. EMD

- 3.1. The bidder shall furnish, as part of its bid, an EMD of the requisite amount. The EMD is required to protect the Company against the risk of Bidder 's conduct which would warrant forfeiture. The EMD shall be denominated in any of the following forms:
 - (a) BG from nationalized / Scheduled Bank, as per the format annexed in the tender document, in favour of BSES Yamuna Power Limited valid for 6(Six) months from original due date of bid submission.
 - (b) Fixed Deposit (lien marked in favor of BSES YAMUNA POWER LTD) valid for 6(six) months from original due date of bid submission.
- 3.2. Please note that bank details as given below have been provided only for the purpose of making BG for EMD.

Beneficiary Name	: BSES Yamuna Power Limited
Bank Name	: State Bank of India (SBI)
A/c No.	: 10277791808
IFSC Code	: SBIN0009601
- 3.3. The EMD of the bidders who are not technically qualified shall be returned after the price bid opening.
- 3.4. Earnest money given by all the bidders who are techno commercially qualified except the lower bidder shall be returned within 8 (Eight) weeks after award of the work.
- 3.5. The EMD of the successful bidder shall be returned on submission of CPBG as per tender terms.
- 3.6. The EMD may be forfeited in case of:
 - (a) The Bidder withdraws its bid during the period of bid validity specified by the Bidder in the Bid Form or

- (b) The successful Bidder does not
 - (i) Accept the Purchase Order/Work Order, or
 - (ii) furnish the required CPBG as per tender terms
- (c) The bidder is found to have submitted false or forged, any of the documents/certificates/information.

4. QUALIFYING REQUIREMENTS (QR)

The prospective bidder must qualify all of the following requirements to be eligible to participate in the bidding. Bidders who meet the following requirements will be considered as the successful bidder and bidder who does not meet these requirements shall be disqualified.

4.1 TECHNICAL QR:

- a) The bidder must have executed at least single order of minimum value Rs 92 Lacs or two orders of minimum value Rs 65 Lacs each or three order minimum value of 52 Lacs each for similar nature of work for 11KV or above level (Cable laying/Transformer Installation/Trenchless work) in the last three financial years (i.e., FY22, FY21 & FY20) for any electric Utilities / SEB's/ Discoms/ Govt. organizations/ Reputed private organization/ OEM.
- b) The bidder shall attach the relevant work orders / Agreement and performance certificate in support of the relevant experience. Credentials/work experience as a sub-contractor will not be acceptable.

4.2 FINANCIAL QR:

- a) The average annual turnover of the Bidder, in the preceding three (3) financial years (i.e., FY22, FY21 & FY20) should not be less than Rs 3 (Three) Crore. The bidder shall submit the Annual Turnover Report of the last 3 FYs duly certified by a Chartered Accountant. The Turnover certificate must have UDIN Number.
- b) The lead bidder must provide proof of having solvency of an amount equal to Rs 0.50 Crore from any nationalized/ scheduled commercial bank. It should not be older than one months from the first date of submission of Techno-Commercial bid.
- c) Bidder should have valid Registration of GST & PAN.
- d) Bidder should fulfil all statutory compliances like PF, ESI registration, etc.
- e) Bidder should have a Valid Electrical License issued by Delhi Govt. for doing electrical works in Delhi region.
- f) Entities that have been currently debarred/blacklisted by any Private/central/state government institution including electricity boards in India, any of the DISCOM in India, lacks qualifying pre-requisites to participate in this tender will not be considered. Accordingly, an undertaking by the Authorized Person along with other documents to be provided by the bidder on its letterhead in this regard, confirming in clear terms, that the contractor has not been debarred/blacklisted as on the date of submission of the bid. Bidders who is currently debarred/ blacklisted/ suspended by BYPL will not be considered in this tender.

- g) The bidder should give an undertaking on their letterhead that all the documents/certificates/information submitted by them against the tender are genuine/true/correct and the copies of documents have been made from the original document/s. Further, in case any of the documents/certificates/information submitted by the bidder is found to be false or, BYPL at its sole discretion shall be free to take all actions as permitted under law, including forfeiture of EMD and disqualification from participation in the future tenders of BYPL & its group companies for an indefinite period or period as may be decided by BYPL.
- h) The bidder should submit an undertaking for “No Litigation / No Legal case” is pending with BYPL or its Group Companies. Bidders having any litigation/ legal case pending with BYPL shall not be considered qualified for this tender.

4.3 OTHER REQUIREMENTS:

- (a) Company reserves the right to carry out technical capability/ infrastructure assessment of the Bidders by factory/office/site inspection or by any other means and company's decision shall be final in this regard.
- (b) No joint ventures /consortiums are allowed.
- (c) The bidder shall submit all necessary documentary evidence to establish that the Bidder meets the above qualifying requirements including but not limited to the following:
- i. Last three Financial Years (FY 19-20, FY 20-21 & FY 21-22) audited financial statement.
 - ii. Bidder to submit UDIN based CA Certificate showing NIL dues towards Statutory Liabilities, including GST, Taxation, PF, ESI, or any other dues Statutory in nature for the period up to 31.03.2022, herein collectively called as “Statutory dues” and there is no liability over the bidder relating to deposition of such statutory dues.
 - iii. Detail of Banks and Fund & Non fund based Credit limit
 - iv. Details of formation/registration of the firm (Proprietary/ Partnership) or Company along with all relevant details)
 - v. Memorandum & Articles of Association of the Company/ Partnership Deed of the Firm /other registration documents, as applicable
 - vi. Organization Chart of the Bidders Company/organisation
 - vii. Organisation chart for execution of the contract
 - viii. Experience details with credentials
 - ix. Number of Employees & necessary details
 - x. Details of office/s in Delhi, Details of Registered and Corporate offices and details of other offices/establishments in India.
 - xi. Work order / Agreement copies along with performance certificates in support of relevant experience

- xii. Turnover certificate issued by CA (along with UDIN no.) for the last three Financial Years.
 - xiii. Net worth certificate as elaborated in financial QR
 - xiv. List of pending litigation with government/other institution on account of executing any order.
 - xv. Copy of ESI/PF Registration certificate
 - xvi. Copy of PAN/GST no.
 - xvii. Copy of GST Return of last Financial Year.
 - xviii. Copy of valid Electrical License
 - xix. Non-Disclosure Agreement (NDA) as per format attached
 - xx. Bidder's details as per format attached
 - xxi. Solvency Certificate
 - xxii. An undertaking to provide all Tools & Plants, PPEs as per tender scope
- (d) The bidder should enclose performance certificates in support of relevant experience.
- (e) For Existing vendors of BYPL, the evaluation will also include the performance in the existing contracts via-a-vis performance in terms of HR issues, all statutory Compliance parameters and wages disbursement by Vendors. BYPL reserves the right to qualify or disqualify their bid based on the contract performance despite them meeting the above-mentioned qualification requirements.
- (f) BYPL may ask for such other documents as it deems fit for substantiating/ justifying the submissions made by the bidder.

5. PRE-BID MEETING:

A pre-Bid meeting shall be organised physically or digitally (through web conferencing platform) at the time and date as specified in the tender documents in the presence of those bidders or their authorized representatives who may choose to be present.

The details of the proposed Zoom Meeting (if applicable) are given below: -

Time : - 09.03.2023, 11:30 HRS India

Meeting ID :- 867 289 9211

Password :- 5678@

All queries related to this tender must reach to C&M Department of BYPL at least three days before the date of the pre- bid meeting. All the bidder's queries shall be replied to in the pre-bid meeting. In case any change is required in the tender document the same shall be effected in the form of corrigendum to this tender. The bidder or their representatives who intend to bid and who have either purchased tender documents or will pay tender fees for downloaded documents are invited to attend the pre-bid meeting. Corrigendum, if any, to the tender document shall be hosted on the website subsequent to the pre-bid meeting. Bidders are requested to submit their offer strictly in line with this tender document& corrigendum if any.

6. BID SUBMISSION

- 6.1. The bidders are required to submit the bid in 2(two) parts and in original& duplicate (total 2 copies) at the following address:

**Head of Department,
Contracts & Material Department,
BSES Yamuna Power Limited,
III Floor, "A" Block, Shakti Kiran Building,
Karkardooma,
New Delhi-110032.**

- 6.2. Technical bid documents along with commercial terms and conditions shall also be submitted in Pen Drive. No price bid shall be submitted in Pen Drive. The PEN Drive should be owned by Bidder. The bidder shall ensure that the Pen Drive is free from all viruses/malware. The pen drive once submitted shall not be returned.
- 6.3. This is a two part bid process. Bidders are to submit the bids in 2(two) parts. Both these parts should be furnished in separate sealed covers super scribing **NIT no. DUE DATE OF SUBMISSION, with particulars as PART-A Techno-Commercial Bid and Part-B PRICE BID** and these sealed envelopes should again be placed in another sealed envelope which should be super scribed with — **"Tender Notice No.& Due date of opening "**. The same shall be submitted before the due date & time specified.

6.3.1 PART A: TECHNO-COMMERCIAL BID, UNPRICED (Envelop-1):

The first sealed envelope shall contain an Unpriced Techno-commercial bid in paper form (hard copies) and envelope super-scribing **PART-A Techno-Commercial Bid**. The details to be submitted in techno-commercial bids are given below:

- a) General information about bidder
- b) Documentary evidence in support of all the qualifying criteria as per clause 4.0,
- c) EMD of requisite amount
- d) Non-refundable separate demand draft for Rs. 1180/- In case the forms are downloaded from the website
- e) Technical Literature if any.
- f) Details of experience of works of the same or similar nature. Copy of work orders and performance certificates.
- g) Power of attorney
- h) Acceptance to Commercial Terms and Conditions viz Delivery schedule/period, Payment terms, BG etc
- i) Any other relevant document to support bidder meeting QR

Techno-Commercial Bid should not contain any cost information whatsoever and shall be submitted within the due date. After techno-commercial evaluation, the list of techno-

commercially qualified bidders will be posted immediately on the BSES website.

The bidder should submit complete tender document along with all corrigendum (if any) published against this NIT at our website, signed and stamped with bidder's seal as an acceptance of all the terms & conditions of the Tender.

6.3.2 PART B: PRICE BID (Envelop-2):

The second sealed envelope shall contain Price bids in paper form (hard copies and envelope super-scribing **PART-B Price Bid** on it. The details to be submitted in the Price bid are given below:

- (a) **PRICE BID** shall Comprise of Prices **strictly** in the Format enclosed in SECTION VII. Any change in price bid format, content may lead to rejection of the bid.
- (b) Price Bid will be opened after techno-commercial evaluation of all the bids and only of the qualified bidders.

6.3.3 FINANCIAL BID EVALUATION THROUGH REVERSE AUCTION

Reverse Auction (RA) shall be conducted for finalization of contract and the details of the price bid shall not be shared with bidders. The qualified bidders will participate in reverse auction through SAP-SRM tool. The RA process shall be governed by the terms and conditions enclosed as Annexure-III in this tender document. Training/details shall be provided to bidders before participation in auction. In case RA is not conducted /concluded for any reasons, a "final no regret" financial bid in a sealed envelope will be called for from all qualified bidders. Notwithstanding anything stated above, the Company reserves the right to assess bidders' capability to perform the contract, should the circumstances warrant such assessment in the overall interest of the Company. In this regard, the decision of the Company shall be final and binding on the bidders.

7. TIME SCHEDULE

The activities and their timelines are given hereunder which needs to be adhered by the bidders.

S. No.	Activity	Description	Due date
1	Submission of Technical & Commercial Queries, if any	All Queries related to NIT	08.03.2023
2	Pre-Bid Meeting	Discussion on pre-bid queries	09.03.2023
3	Submission of Techno-Commercial & Price Bid	Unpriced Techno-Commercial & Price Bid in separate sealed envelopes	14.03.2023

4	Opening of Techno-Commercial Bid	Opening of PART-A	15.03.2023
5	Opening of Price Bid	Opening of PART-B of only the techno-commercially qualified bidders (List of bidders will be published at our website)	To be informed separately
6	Reverse Auction	As per RA terms	Schedule will be intimated to eligible bidders through email from email id: BYPL.Eauction@relianceada.com

8. AWARD DECISION

- 8.1. Company intends to award the business on a lowest bid basis, so bidders are encouraged to submit the bid competitively. The decision to place order/LOI solely depends on Company on the cost competitiveness across multiple lots, quality, delivery and bidder 's capacity, in addition to other factors that Company may deem relevant.
- 8.2. The Company reserves all the rights to award the contract to one or more bidders who meet the execution requirement or nullify the award decision without assigning any reason thereof.
- 8.3. In case the performance of any contractor is found unsatisfactory during the execution process, the award will be cancelled and BYPL reserves the right to award the work to another contractor(s) who will be found eligible/fit.
- 8.4. The abnormally higher or abnormally lower bids shall not be considered with respect to estimated cost. The criteria decided by BYPL on this shall be final and binding on the bidders.
- 8.5. The bidding firms are advised to quote their Margin / Administrative Service Charges accordingly. BYPL reserves the right to reject the bids quoted with abnormally higher or abnormally lower individual activity rates. The criteria decided by BYPL on this shall be final and binding on the bidders and will not be open for discussion under any circumstances.

9. MARKET INTEGRITY

We have a fair and competitive marketplace. The rules for the bidders are outlined in the Terms & Conditions of the tender documents. Bidders must agree to these rules prior to participating in the tender. In addition to other remedies available, we reserve the right to exclude a bidder from participating in future markets due to the bidder's violation of any of the rules or obligations contained in the Terms & Conditions. Bidder(s) who violate the marketplace rules or engage in behaviour that disrupts the fair execution of the marketplace restricts a bidder from participation in future tenders of BYPL to a length of time as decided by BYPL, depending upon the seriousness of the violation. Examples of violations include, but are not limited to:

- Failure to honour prices submitted to the market place.

- Breach of the terms published in Request for Quotation/NIT
- Misrepresentation of facts, submitting false and fabricating documents

10. CONFIDENTIALITY

All information contained in this tender document is confidential and may not be disclosed, published or advertised in any manner without written authorization from BYPL. This includes all bidding information submitted.

All tender documents remain the property of BYPL and all bidders are required to return these documents to BYPL upon request.

Bidder(s) who do not honour these confidentiality provisions will be excluded from participating in future bidding events.

The bidder shall sign a Non-Disclosure Agreement (NDA) in the format attached in tender document and submit along with its bid.

11. CONTACT INFORMATION

Technical & Commercial clarification, if any, regarding this tender shall be sought in writing and sent by e-mail to the following e-mail IDs:

Address	Name/ Designation	Email Address / Phone Number
Technical & Commercial		
C&M Dept, 3rd Floor, A Block, BSES Yamuna Power Ltd Shakti Kiran Building, Karkardooma, New Delhi110032	Mr. Abhinav Sharma, GM – (C&M)	Abhinav.k.sharma@relianceada.com / 0114124 9315
	Mr.Santosh Srivastava, Head – (Contracts)	Santosh.V.Srivastava@relianceada.com / 0114124 9850
	Mr. Robin Sebastian, Head – (C&M)	Robin.Sebastian@relianceada.com / 0114124 9230

SECTION-II : INSTRUCTIONS TO BIDDERS (ITB)

SECTION-II
INSTRUCTIONS TO BIDDERS (ITB)

1. GENERAL

BSES YAMUNA Power Ltd (BYPL), hereinafter referred to as the “Company” is desirous for awarding work of “Electrification of East Delhi Hub, Karkardooma near karkardooma Metro Station Scheme no. JM22EL2013” as notified in this tender document.

- 1.1 All the Bids shall be prepared and submitted in accordance with these instructions.
- 1.2 Bidder shall bear all costs associated with the preparation and delivery of its Bid, and the Company will in no case shall be responsible or liable for these costs.
- 1.3 The Bid should be submitted by the Bidder in whose name the bid document has been issued and under no circumstances it shall be transferred /sold to the other party.
- 1.4 The Company reserves the right to request for any additional information/documents and also reserves the right to reject the proposal of any Bidder, if in the opinion of the Company, the data in support of RFQ requirement is incomplete.
- 1.5 The Bidder is expected to examine all instructions, forms, terms & conditions and specifications in the Bid Documents. Failure to furnish all information required in the Bid Documents or submission of a Bid not substantially responsive to the Bid Documents in every respect may result in rejection of the Bid. However, the Company’s decision in regard to the responsiveness and rejection of bids shall be final and binding without any obligation, financial or otherwise, on the Company.
- 1.6 The company reserves the right to split the order among various successful bidders in any manner it chooses without assigning any reason whatsoever.

2. SCOPE OF WORK

Detailed specification/scope of work is provided in Section-V of this tender document.

3. DISCLAIMER

- 3.1. This NIT is not an agreement and further it is neither an offer nor an invitation by BYPL to bidders or any other person for award of contract. The purpose of this NIT is to provide bidders information that may be useful to them in the preparation and submission of their bids.
- 3.2. This Document includes statements, which reflect various assumptions, which may or may not be correct. Each Bidder should conduct its own estimation and analysis and should check the accuracy, reliability and completeness of the information in this Document and obtain independent advice from appropriate sources in their own interest.

- 3.3. Neither Company nor its employees will have any liability whatsoever to any Bidder or any other person under the law or contract, the principles of restitution or unjust enrichment or otherwise for any loss, expense or damage whatsoever which may arise from or be incurred or suffered in connection with anything contained in this Document, any matter deemed to form part of this Document, provision of Services and any other information supplied by or on behalf of Company or its employees, or otherwise arising in any way from the selection process for the Work.
- 3.4. Though adequate care has been taken while issuing the Tender document, the Bidder should satisfy itself that Documents are complete in all respects. Intimation of any discrepancy shall be given to this office immediately.
- 3.5. This Document and the information contained herein are Strictly Confidential and are for the use of only the person(s) to whom it is issued. It may not be copied or distributed by the recipient to third parties (other than in confidence to the recipient 's professional advisors).
- 3.6. It shall be deemed that by submitting a bid, a bidder agrees to release BYPL and its employees, agents and advisors irrevocably unconditionally fully and finally from any and all liability for any claims losses damages costs expenses or liabilities in anyway related to or arising from exercise of any rights and all performance of any obligations under this NIT and or in connection with the bid process to the fullest extent permitted by applicable law and waives any and all rights and all claims it may have in this respect whether actual or contingent whether present or in the future
- 3.7. BYPL and its employees and advisors also accept no liability of any nature whether resulting from negligence or otherwise arising from reliance of any bidder upon the contents of this NIT. BYPL may in its absolute discretion but without being under any obligation to do so, update amend or supplement the information assessment statement or assumptions contained in this NIT.
- 3.8. The issue of this tender document does not imply that BYPL is bound to qualify any bidder or to award the contract to any bidder. BYPL reserves the right to reject all or any of the bids without assigning any reasons whatsoever.

4. COST OF BIDDING

The Bidder shall bear all cost associated with the preparation, submission and processing of its Bid and the company will in no case be responsible or liable for the costs.

5. TENDER DOCUMENTS

- 5.1. The Scope of Work, Bidding Procedures and Contract Terms are described in the Bidding Documents. In addition to the covering letter accompanying Bidding Documents, the Bidding Documents include:

“Check List, Sections, Annexure & Formats as elaborated in CONTENT of this NIT.”

- 5.2. The bidder is expected to examine the tender documents, including all Instructions, Forms, Terms and Specifications. Failure to furnish all information required by the tender documents or submission of a bid not substantially responsive to the tender documents in every respect may result in the rejection of the Bid.

6. AMENDMENT OF TENDER DOCUMENTS

- 6.1. At any time prior to the deadline for submission of Bids, the Company may for any reason(s), whether at its own initiative or in response to a clarification requested by a prospective Bidder, alter/amend/modify the tender documents by corrigendum /amendment.

- 6.2. The corrigendum / amendment shall be part of tender document, pursuant to Clause 5.1, and it will be notified
- (a) by way of uploading the corrigendum/amendment on BSES website (in case of public tender),
 - (b) in writing by e-mail to all the Bidders who have received the Bidding Documents by email. (in case of limited tender)

All such corrigendum & amendments will be binding on the bidders.

- 6.3. In order to provide prospective Bidders a reasonable time in which to take the Amendment into account in preparing their Bids, the Company may, at its discretion, extend the deadline for the submission of Bids.

7. PREPARATION OF BIDS & LANGUAGE

The Bid prepared by the Bidder, and all correspondence, documents etc. relating to the Bid exchanged by the Bidder and the Company shall be written in English Language. Any printed literature furnished by the Bidder may be written in another Language, provided that this literature is accompanied by English translation, in which case, for purposes of interpretation of the Bid. In case of ambiguity in the English translation, interpretation of the Company as regards to translation will be final.

8. DOCUMENTS COMPRISING THE BID

The Bid prepared and submitted by the Bidder shall comprise the following components:

- (a) Techno-Commercial Bid & Price Bid as elaborated in RFQ. (STRICTLY AS PER FORMAT)
- (b) All the Bids must be accompanied with the required EMD & Tender Fees against each tender.

9. BID FORM

The Bidder shall complete "Original" Bid Form and submit it along with details mentioned in Techno-Commercial bid (without filling price).

10. BID PRICES

Bidders shall quote for the entire Scope of work with prices for individual items. The bidder is required, at his expense, to obtain all the information he may require to enable him to submit his tender including necessary visits to the site to ascertain the local conditions, procurement of necessary materials, labour, etc., requirements of the local/government/public authorities in such matters.

11. BID CURRENCIES

Prices shall be quoted in Indian Rupees Only.

12. PERIOD OF VALIDITY OF BIDS

- 12.1. Bids shall remain valid & open for acceptance for a period of 180 days from the date of opening of the Bid.
- 12.2. Notwithstanding above, the Company may solicit the Bidder 's consent to an extension of the Period of Bid Validity and the bidder shall be liable to extend the same at the sole cost and consequences of the bidder and no claim from the company in this regard shall be maintainable.

13. ALTERNATIVE BIDS

Bidders shall submit Bids, which comply with the Tender Documents. Alternative Bids will not be considered. The attention of Bidders is drawn to the provisions regarding the rejection of Bids in the terms and conditions, which are not substantially responsive to the requirements of the Tender Documents.

14. FORMAT AND SIGNING OF BID

- 14.1. The original Bid Form and accompanying documents (as specified in Clause 9.0), clearly marked "Original Bid", must be received by the Company at the date, time and place specified in Section-I, RFQ.
- 14.2. The original copy of the Bid shall be typed or written in indelible ink and shall be signed by the Bidder or a person or persons duly authorized to sign on behalf of the Bidder. Such authorization shall be indicated by written Power-of-Authority accompanying the Bid. All pages of the bid shall be signed by the signatory accompanied with seal of the Agency.
- 14.3. The Bid shall contain no interlineations, erasures or overwriting except as necessary to correct errors made by the Bidder, in which case such corrections shall be signed by the person or persons signing the Bid.

15. SEALING AND MARKING OF BIDS

- 15.1. Bid submission: One original (hard copies) and one duplicate (total two copies) of all the Bid Documents shall be sealed and submitted to the Company before the closing time for submission of the bid.
- 15.2. The Bidder has the option of sending the Bids in person. Bids submitted by Email/Telex/Telegram /Fax will be rejected. No request from any Bidder to the Company to collect the proposals from Courier/Airlines/Cargo Agents etc shall be entertained by the Company.

16. DEADLINE FOR SUBMISSION OF BIDS

- 16.1. The Original bid must be timely received by the company at the address specified in Section –I, RFQ.
- 16.2. The Company may, at its discretion extend the deadline for the submission of bids by amending the Tender Documents in accordance with Clause 6.0, in which case all rights and obligations of the Company and Bidders previously subject to the deadline will thereafter be subject to the deadline as extended.

17. ONE BID PER BIDDER

Each Bidder shall submit only one Bid by itself. A Bidder who submits or participates in more than one Bid will cause all those Bids to be rejected.

18. LATE BIDS

Any Bid received by the Company after the deadline for submission of Bids prescribed by the Company, pursuant to Clause 16.0, will be declared "Late" and rejected and returned unopened to the Bidder.

19. MODIFICATIONS AND WITHDRAWAL OF BIDS

The Bidder is not allowed to modify or withdraw its Bid after the due date of bid submission.

20. EVALUATION OF BID

- 20.1. The bids will be evaluated techno-commercially on compliance to tender terms and Conditions.
- 20.2. BYPL reserves the right to ask the bidders to provide any additional information including breakup of the prices as quoted by them against line items.

21. CLARIFICATION OF BIDS

To assist in the examination, evaluation and comparison of Bids, the Company may, at its discretion, ask the Bidder for a clarification of its Bid. All responses to requests for

clarification shall be in writing and no change in the price or substance of the Bid shall be sought, offered or permitted

22. PRELIMINARY EXAMINATION OF BIDS / RESPONSIVENESS

- 22.1. Company will examine the Bids to determine whether they are complete, whether any computational errors have been made, whether required sureties have been furnished, whether the documents have been properly signed, and whether the Bids are generally in order.
- 22.2. Arithmetical errors will be rectified on the following basis. If there is a discrepancy between the unit price and the total price per item that is obtained by multiplying the unit price and quantity, the unit price shall prevail and the total price per item will be corrected. If there is a discrepancy between the Total Amount and the sum of the total price per item, the sum of the total price per item shall prevail and the Total Amount will be corrected.
- 22.3. Company will determine the substantial responsiveness of each Bid to the Tender Documents including execution capability and acceptable quality of the services offered. A substantially responsive Bid is one, which conforms to all the terms and conditions of the Tender Documents without deviation.
- 22.4. Bid determined as not substantially responsive will be rejected by the Company and may not subsequently be made responsive by the Bidder by correction of the non-conformity.

23. EVALUATION AND COMPARISON OF BIDS

- 23.1. The evaluation of Bids shall be done based on the delivered cost competitiveness basis.
- 23.2. The evaluation of the Bids shall be a stage-wise procedure. The following stages are identified for evaluation purposes: In the first stage, the Bids would be subjected to a responsiveness check later on the Techno-Commercial Proposals and the Conditionality of the Bidders would be evaluated.
- Subsequently, the Financial Proposals along with Supplementary Financial Proposals, if any, of Bidders with Techno-commercially Acceptable Bids shall be considered for final evaluation.
- 23.3. The Company's evaluation of a Bid will take into account, in addition to the Bid price, the following factors, in the manner and to the extent indicated in this Clause:
- (a) Contract completion schedule
 - (b) Conformance to Qualifying Criteria
 - (c) Deviations from Tender Documents
 - (d) Conformity and compliance to the conditions/details provided in pre-bid meeting
 - (e) Change in the quantity from mentioned in the tender
- 23.4. The cost of all quantifiable deviations and omissions from the specification, terms and conditions specified in Tender Documents shall be evaluated.
- 23.5. The Company will make its own assessment of the cost of any deviation for the purpose of ensuring fair comparison of Bids.

- 23.6. Adjustments in price, if any, based on the above procedures, shall be made for the purposes of comparative evaluation only to arrive at an "Evaluated Bid Price". Bid Prices quoted by Bidders shall remain unaltered.

24. CONTACTING THE COMPANY

- 24.1. From the time of Bid opening to the time of contract award, if any Bidder wishes to contact the Company on any matter related to the Bid, it should do so in writing.
- 24.2. Any effort by a Bidder to influence the Company and/or in the Company's decisions in respect of Bid evaluation, bid comparison or Contract Award, will result in the rejection of the Bidder 's Bid.

25. COMPANY 'S RIGHT TO ACCEPT ANY BID AND TO REJECT ANY OR ALL BIDS

The Company reserves the right to accept or reject any Bid and to annul the Bidding process and reject all Bids at any time prior to award of Contract, without thereby incurring any liability to the affected Bidder or Bidders or any obligation to inform the affected Bidder or Bidders of the grounds for the Company's action.

26. AWARD OF CONTRACT

The Company will award the Contract to the successful Bidder whose Bid has been determined to be the lowest-evaluated responsive Bid, provided the Bidder has been determined to be qualified to satisfactorily perform the Contract. Company reserves the right to award order to other bidders in the tender, provided it is required for need of the work. The full or part of the contract may be awarded to other bidder(s) on differential rates.

27. THE COMPANY'S RIGHT TO VARY QUANTITIES

The Company reserves the right to vary the quantity i.e. increase or decrease the Numbers/ quantities without any change in terms and conditions before the award of Contract. Further BYPL may increase or reduce the area/ scale of operations / increase or decrease the Numbers/ quantities after the start of work execution under the contract and the size of contract / contract value shall be adjusted accordingly. In case of decrease in base resources decided mutually then contract value will be adjusted accordingly.

28. LETTER OF INTENT/ NOTIFICATION OF AWARD

The letter of intent/ Notification of Award shall be issued to the successful Bidder whose bids have been considered successful for award of work/order.

The successful Bidder shall be required to furnish acceptance of LOI / notification of award within 7 days of issue of the letter of intent /Notification of Award by Company.

29. CORRUPT OR FRAUDULENT PRACTICES

29.1. The Company requires that the Bidders observe the highest standard of ethics during the entire period of work execution under the Contract. In pursuance of this policy, the Company:

(a) Defines, for the purposes of this provision, the terms set forth below as follows:

"Corrupt practice" means behaviour on the part of officials in the public or private sectors by which they improperly and unlawfully enrich themselves and/or those close to them, or induce others to do so, by misusing the position in which they are placed, and it includes the offering, giving, receiving, or soliciting of anything of value to influence the action of any such official in the procurement process or in contract execution; and "Fraudulent practice" means a misrepresentation of facts in order to influence a award process or the execution of a contract to the detriment of the Company, and includes collusive practice among Bidders (prior to or after Bid submission) designed to establish Bid prices at artificial non-competitive levels and to deprive the Company of the benefits of free and open competition.

(b) Will reject a proposal for award if it determines that the Bidder recommended for award has engaged in corrupt or fraudulent practices in competing for the contract in question;

(c) Will declare a firm ineligible either indefinitely or for a stated period of time, to be awarded a contract if it at any time determines that the firm has engaged in corrupt or fraudulent practices in competing for, or in executing, a contract.

29.2. Furthermore, It shall be the responsibility of the Bidders to read and understand & aware of the provision stated in the Terms and Conditions of tender before participating in the tender.

30. PROCESS TO BE CONFIDENTIAL

Information relating to the examination, clarification, evaluation and comparison of Bids and recommendations for the award of a contract shall not be disclosed to Bidders or any other persons not officially concerned with such process. Any effort by a Bidder to influence the Company's processing of Bids or award decisions may result in the rejection of the Bidder's Bid.

SECTION – III : SPECIAL CONDITIONS OF CONTRACT (SCC)

SECTION – III:

SPECIAL CONDITIONS OF CONTRACT (SCC):

These Special Conditions of Contract (SCC) shall be read in conjunction with the Terms and Conditions of the Contract, General Conditions of Contract (GCC), Scope of Work and other documents forming part of the contract wherever the context so requires. Notwithstanding the subdivision of documents into separate sections and volumes, every part of each such document shall be deemed to be supplementary to and complementary of every other part.

1. DEFINITIONS

ENGINEER IN-CHARGE (EIC) / OFFICER-IN-CHARGE (OIC)

The term "Engineer-in-charge (EIC) / Officer-in-Charge (OIC)" shall mean the Company's nominated representative for the purpose of supervision of the execution of the Contract. The same shall be mentioned in the Contract.

2. SCOPE OF WORK

The scope includes material transportation, GPR Survey of Route, digging of trench, cable laying, supply of HDPE pipe, cable cover, Backfilling of trench, Covering of Malba, Dust mitigation Measures at Site, close Barricading, Removal of Surplus Malba, ETC of Transformer of various rating ,VCB, CT, PT, LA, Isolator, C&R Panel, BMK, Laying of control cable, Fabrication and Erection of Steel Structure, Stringing of Bus Bar, Plinth for distribution transformer etc as per detailed scope of work as enumerated in Section – V. Vendor is responsible for taking the Permission from Road owning agencies & Delhi Police, statutory fees will be borne by BYPL. Electrical Inspector Clearance fees shall be in Bidder's scope. The related fees, payments and pursuance work shall be in scope of Bidder only.

3. EFFECTIVE DATE, TIME AND VALIDITY

- 3.1 The order/agreement shall become effective for all purposes from the date to be specified under the agreement and continue to remain in force for the period of 180 days.
- 3.2 You are required to mobilize your manpower within 7 days of receipt of WO and commence the activity as per instructions of Engineer In-charge. The entire work should be completed within 180 days from the date of issue of order.
- 3.3 The detailed schedule and milestone completion dates would be as per the contract schedules given from time to time by Engineer In-charge at site. You shall submit a weekly progress report to Engineer In charge.

4. ORDER VALUE

Value of the contract will be contracted out on the basis of finalized rates.

The Contractor shall not be entitled to adjustment in the Service Fees during the term of this Agreement for increase due to-

- (a) increased labour costs or costs related to vehicles or other Equipment's provided,
- (b) changes in insurance premiums, and/or
- (c) changes in legislations or regulations relating to the Service.
- (d) The cost of insurance during loading/unloading of materials/ equipment's during its storage and handling/erection at site for installation is included in the contractor's scope and value will be included in the work order value. The unit rates are also inclusive of barricading charges and watch & ward charges during execution and no separate charges shall be paid for the same.

5. RATES & ESCALATION

5.1 The Rates/Agreement Consideration are firm and fixed for the Agreement period. The Rates shall not be subject to escalation or increases on any account /reason(s) whatsoever.

5.2 The rates set out above are also inclusive of reasonable incidental expenses incurred by Contractor on the following:

- I. Cost of Labour, tackles and supervision.
- II. All taxes and levies, including but not limited to GST, etc. as applicable during the currency of the contract.
- III. -
- IV. -
- V. Rates shall be valid for all heights and locations.
- VI. All other expenses incidental to the job.
- VII. The Company shall pay only once against the service provided irrespective of the fact that the Contractor might have to take more than one attempts for providing the service.
- VIII. Compliance with all labour laws including Minimum Wage Act, Bonus Act, The Sexual Harassment of Women at Workplace (Prevention, Prohibition and Redressal) ACT, 2013etc in respect of employees engaged by the Contractor for the discharge of services as per this agreement.

6. CONTRACT CUM PERFORMANCE SECURITY BANK GUARANTEE (CPBG)

6.1 Contractor shall furnish the CPBG in the prescribed format within 15 days from the date of issue of LOI / Work Order for due performance of the provisions of Work Order/Agreement.

- 6.2 The contract Performance Bank Guarantee shall be of 10% of the initial contract value and shall be valid till the completion of defect liability period plus three (3) months or latest RBI guidelines (if any) whichever is higher towards claim period, if not otherwise specified in agreement. This amount shall remain fixed during the currency of the agreement.
- 6.3 The CPBG shall be issued from any nationalized / scheduled bank as per company format.
- 6.4 The Company shall reserve the right to invoke the CPBG unconditionally and without recourse to the Contractor, if there is failure to perform any part of the Agreement for whatsoever reason. This clause is pertaining to performance of contractual obligations and the decision of Company shall be final in this regard.
- 6.5 In the event of any claim or any other outstanding Contractual obligations remaining unfulfilled, the Contractor shall be required to extend the CPBG till the settlement of all claims and completion of all Contractual obligations at the cost and consequences of contractor.
- 6.6 In the event, in Company's sole judgement, the Contractor has fulfilled all its obligations under this Agreement, The CPBG shall be released without any interest after the expiry of CPBG and its claim period as mentioned above.
- 6.7 If the CPBG is or becomes invalid for any reason (other than its expiry), the Contractor shall immediately notify the Company/BYPL and provide within five (5) days a replacement CPBG in the form set out in the Contract/Agreement.
- 6.8 Not later than sixty (60) Business Days before the expiry of the CPBG, the Contractor shall, upon request of the Company/BYPL obtain extension of the validity of such CPBG for the period stated in such request by the Company/BYPL and provide a copy of such renewed CPBG.
- 6.9 It is Contractor's responsibility to incur charges / cost to maintain and for extension of CPBG without claiming reimbursement from the company/BYPL.

7. PAYMENT TERMS:

Payment shall be made to you as under:

- 7.1 80% payment shall be released on submission of bill and certification of work completion by Engineer-In-charge. The bill shall be paid within 30 days on receipt of such bills at our office.
- 7.2 10% against submission of Electrical Inspectorate's & QC clearance certificate.
- 7.3 Balance 10% shall be paid on testing and commissioning of entire scheme, work completion certificate issued by our Engineer in charge.

- 7.4 The Invoice shall be processed and payment shall be made to contractor on certification of Engineer-In Charge for compliance to check point's given in check list.
- 7.5 The contractor shall submit original bill (hard copy) along with all supporting documents at Vendor Support Cell of BYPL. The bills shall be made in favour of BSES Yamuna Power Ltd, Shakti kiran Building Karkardooma, New Delhi - 110032.
- 7.6 Company shall make payments, without any interest/charges and after deduction of taxes, penalties as applicable, against the bills within 30 days from the date of receipt of the bills, duly verified and certified by Engineer-in-Charge.
- 7.7 Contractor shall, at no point of time, claim or have the right to claim any additional fees, expenses or charges of any nature whatsoever, other than the Rates set out in the contract.
- 7.8 The company may modify the procedure for the submission of bills. The Contractor shall be obliged to submit its bill as per the procedure stipulated by the company from time to time.

8. LIQUIDATED DAMAGES & PENALTY

- 8.1 In the event of any delay in completion of the work beyond the stipulated time given by in order due to reasons solely attributable to the Contractor, the Contractor shall pay to the Company liquidated damages.
- 8.2 If the Contractor failed perform the services within the time period specified in the order, the Company shall, without prejudice to its other remedies under the contract, deduct liquidated damages a sum equivalent to 2.0% of the billed amount of final work executed for each week or part there of delay until the actual date of completion up to a maximum deduction of 20% of billed amount of final work executed. Once the maximum is reached to Company may consider termination of contract without any liabilities to Company.
- 8.3 Penalty related to HR issues & ID Cards shall be applicable as defined in GCC.
- 8.4 Penalty for noncompliance of statutory regulations shall be applicable as defined in GCC.
- 8.5 Penalty for misconduct/failure in performance of task under the agreement shall be applicable as defined in GCC.
- 8.6 Penalty for violation of safety & quality norms shall be applicable as defined in Annexure IV, EHS Conditions of the Contract.

9. DERC GUIDELINES & REGULATIONS

The bidder shall make himself fully aware & familiarise with prevailing DERC guidelines / regulations.

10. INSURANCE POLICIES

The contractor shall take suitable insurance policy for its men and materials (Term Insurance for life , GPA, Mediclaim policy, Workmen Compensation Policy etc.)as listed below for the resources deployed by him:

10.1 Group Personal Accident Insurance:

Before commencing the execution of the work the Contractor shall take Accidental insurance policy for the staff engaged/deployed by him for the work under agreement, to insure against any loss of life which may occur during the agreement for the work of the Company. The policy shall have coverage of Rs. 15 Lakh (Table C Death + Permanent Total Disability + Partial permanent Disability due to external accidents). Permanent total disability coverage shall be 125% of the basic sum assured of Rs 15 Lakh.

The Contractor shall be responsible for on the spot same day claim settlement with the victim's legal heirs without waiting for settlement by insurance claim and without any liability on BYPL. The premium amount for both the above policies shall be borne by the Contractor. The Contractor shall furnish copy of policy within 15 days of start of work under the contract.

10.2 Medical Insurance Policy:

Contractor shall take a mediclaim policy including family floater of minimum sum assured value Rs. 2.00 lakhs for the resources who are not covered under ESI.

10.3 Comprehensive Marine Storage cum Erection insurance policy:

Company shall take at his own cost Comprehensive Marine Storage cum Erection insurance policy for the total work. However, Contractor shall take at his own cost third party insurance and other suitable insurance policy for his own men and materials. Please note that these insurance policies shall be taken in consultation with the company and a copy of the such insurance policies shall have to be furnished to company within 15 days of the date of LOI/Order.

- 10.4 For all the insurance policies (whether taken by the Company or Contractor), the Contractor shall be responsible for settlement of claims with the underwriters without any liability on the company and will arrange replacements / rectification expeditiously without a waiting settlement of insurance claim, at contractor's own cost and this shall not entitle the Contractor for any extension of time.

11. WARRANTY / DEFECT LIABILITY PERIOD

The Contractor shall be liable to rectify all defects in the materials or works done by the Contractor under this Contract, or from any act or omission of the contractors for a period of Twelve (12) months from date of final work completion certification by the Engineer in-charge.

If any defect noticed and system cannot be used by reason of any defect, the defect liability period shall be extended by the period equal to the period during which the system is not in operation.

In respect of any warranty work performed by the Contractor, the period during which a claim may be made for such warranty work shall be extended by an additional period of twelve (12) months from the completion of such portion of warranty work.

BSES

SECTION – IV : GENERAL CONDITIONS OF CONTRACT (GCC)

BSES

SECTION – IV

GENERAL CONDITIONS OF CONTRACT (GCC)

This GCC shall form an integral part of the Agreement and will be of full force and effect as if they were expressly set out in the body of the Agreement.

Reference to any legislation or law to any provision thereof shall include references to any such law as it may, after the date hereof, from time to time, amended, supplemented or re-enacted, and any reference to a statutory provision, shall include any subordinate legislation made from time to time under that provision.

1. DEFINITION & INTERPRETATION

1.1. Definition

In the Agreement (as defined below) the words and expressions defined below shall have the meanings assigned to them herein except where the context requires otherwise:

- 1.1.1. “Accounting Year” means the financial year commencing from 1 April of any calendar year and ending on 31 March of the next calendar year.
- 1.1.2. “Applicable Laws” means all Law / Laws in force and effect, as of the date hereof and which may be promulgated or brought into force and effect hereinafter in India including any revisions, amendments or re-enactments including without limitation regulations, rules and notifications made there under and judgments, decrees, injunctions, writs and orders of any court or regulators or quasi-judicial body or any appropriate authorities, as may be in force and effect during the subsistence of the Contract. It includes Law/Laws of Country/State legislation, statues, ordinance, notification, circular, regulations and other Laws, and bye Laws of any legally constituted public authority.
- 1.1.3. “Change in Law” means the occurrence of any of the following after the execution of agreement:
- (i) The enactment of any new Indian Law;
 - (ii) The repeal, modification or re-enactment of any existing Indian Law;
 - (iii) The commencement of any Indian Law which has not entered into effect until the date of performance the Contract;
 - (iv) Change in the interpretation or application of any Indian Law by a court as compared to such interpretation or application twenty-eight (28) days prior to the last date of submission of Tender;
 - (v) It also includes changes in the tax rates upward or downward.
- 1.1.4. “Change in Service” means any addition to, deletion from, suspension of or other modification, to the Services, or to the quality, function or as delineated in this agreement, including any such addition, deletion, suspension or other modification, which requires a change in one or more of the service specification and the completion schedule.

- 1.1.5. "Communication" means instruction or information or written notice issued on letter head or through electronic mail exchange between Parties and excludes verbal or short messaging services (SMS). The notice shall be served by delivering a copy by electronic mail, or registered post/speed post etc. Unless otherwise stated in the agreement, all communications to be given under the Contract shall be in writing. Communication may be sent to competent authority or authority delegated to such officer/employee. Communication shall be on letter head of Party signed by competent authority/authorized signatory of the Party.
- 1.1.6. "Company/Owner/Purchaser/First Party " the terms used in this agreement shall refer to BSES YAMUNA Power Limited (BYPL) having its office at Shakti Kiran Building, Karkardooma, Delhi-110032 and shall include its authorized representatives, agents, successors and assignees.
- 1.1.7. "Contractor/Agency/Vendor" means the successful bidder to whom this Agreement is awarded. It is entity named in the Execution Cover and includes assignees, administrator, executors, successors, associated company/subsidiary/joint venture/firm/representative of the Contractor. It is also termed as 'Contractor' or 'Agency'.
- 1.1.8. "Contract" / " Agreement"/"Work Order" means the agreement between the Company and the Contractor for the performance of the Services, including the Contract / Agreement/ Work Order duly signed and executed between the Parties, the letter of acceptance, the Conditions of Contract, the schedules, Annexures, the Company/BYPL's requirements, including but not limited to the tender, other tender documents and such further documents which are listed in the Contract / Agreement/Work Order and includes any amendment thereto made in accordance with the provisions hereof giving binding effect to the terms and conditions agreed by the Parties. This includes Work Order / Letter of Intent(LOI) issued to the Contractor by the Company/BYPL.
- 1.1.9. "Agreement Period" shall mean duration of Services to be performed and includes extension thereof after mutual consent of both Parties.
- 1.1.10. "Agreement Value/Consideration" means the price of the defined Services including taxes payable to the Contractor for the performance of the Services subject to such additions thereto and deductions there from as may be made under the provisions of this Agreement. The Agreement Value is in consideration of providing the Service by the Contractor as per scope of work and as per Service specifications stipulated in the Agreement; the Agreement Value includes all and any fees, charges, local cess, taxes (GST and Income Tax), levies together with all cost and expenses. The Agreement Value may also term as 'Service Fee(s)' or 'Agreement fees'/Consideration elsewhere in the Agreement. Agreement Value is fixed lump sum for the Agreement Period unless mentioned in Agreement elsewhere.
- 1.1.11. "Force Majeure" shall have the meaning as ascribed in this agreement and annexures thereto.

- 1.1.12. “Good Industry Practice” means the exercise of the highest degree of skill, diligence, prudence and foresight in compliance with the obligations under the Contract which would be expected from a skilled and experienced Contractor engaged, being internationally accepted and customized in day to day performance in industry including for the supply of Manpower.
- 1.1.13. “HSE Conditions” shall mean the BYPL’s health, safety and environment conditions containing the requirements and conditions to be met with respect to safety, health and environment.
- 1.1.14. “KPI” shall mean Key Performance Indicator as set out in the Contract/Agreement, its schedules/annexures etc. The performance of the Manpower employed by the Contractor for execution of Services shall be measured through KPI. The payment to Contractor shall be based on Manpower’s performance as measured through KPI. It includes metrics in numerical, frequency and measuring process. Total manpower shall be monitored & calculated skill wise but it will be cumulative on monthly basis
- 1.1.15. “Manpower” means a person/s, labour (including Contractor’s staff / personnel) known, introduced, security personnel employed and deployed by the Contractor in Contractor’s provision of the Services who has skill, efficiency and mannerism to execute, perform Services under this Contract as per Scope Of Work of the Contract. The Manpower deployed shall have valid licenses, PAN card details / KYC information.
- 1.1.16. “Contract cum Performance Bank Guarantee (CPBG)” means the bank guarantee to be procured in accordance with terms of agreement for the performance of the Contractor’s obligations under the Contract. The CPBG format is furnished in the Annexure, annexed to agreement.
- 1.1.17. “Service(s)” / “Works” shall mean Company/BYPL’s requirements describing in detail including the nature of the Services and activities to be performed by the Contractor and its Manpower, in accordance with specifications, the duration of such requirement, and Services performed, the expected time of commencement and completion, detailed responsibilities and other relevant particulars. It is ‘scope of work’ which is to be executed, performed successfully and satisfactorily by the Contractor in accordance with the Contract and ancillary services as may be Communicated by the BYPL from time to time under the Contract Period.
- 1.1.18. “Site” means the designated place/office or establishment or construction site, office, branch, including right of way and/or places provided by the BYPL where the Services is to be executed and any other place as may be specifically designated in the Contract/Agreement as forming part of the Site or designated as such by the Company/BYPL.

- 1.1.19. "Sub-Contractor" means a Sub-Contractor whom a part of the Contract is Sub Contracted by the Contractor with the prior written approval of the Company/BYPL, and the permitted legal successors in title to such person, but not any assignee of such person.
- 1.1.20. "Sub-Contract" shall mean obligations under the Contract have been awarded by the Contractor to Sub-Contractor.
- 1.1.21. "Tax Invoice" /" Running Bill" (RA Bill/bill) shall have the meaning ascribed to it under GST Laws.

1.2. Interpretation

In the Contract except where the context requires otherwise:

- 1.2.1. Words indicating one gender include all genders
- 1.2.2. "Written" or "in writing" means hand-written, written, or electronically made and resulting in a permanent record.
- 1.2.3. Any reference to any provision of an act of Parliament or of a state legislature shall be construed, at the particular time, as including a reference to any modification, extension or re-enactment thereof, to all instruments, orders or regulations then in force
- 1.2.4. The singular shall include plural and vice versa, and words denoting natural persons shall include partnerships, firms, companies, corporations, joint ventures, trusts, associations, organizations or other entities
- 1.2.5. The headings are inserted for convenience and shall not limit, alter or affect the meaning of the Contract.
- 1.2.6. The terms defined in schedule and the BYPL's Requirements shall have the same meaning ascribed thereto when used elsewhere in the Contract and vice versa;
- 1.2.7. The words "include" and "including" shall be construed without limitation.
- 1.2.8. The schedules/annexures shall form an integral part of the Conditions of Contract and shall be in full force and effect as though they were expressly set out in the body of the Conditions of Contract.
- 1.2.9. The word "consent" wherever used, shall mean prior written consent;
- 1.2.10. In the event any portion or all of the Contract is held to be void or unenforceable, the Parties agree to negotiate in good faith to arrive at an amicable understanding which shall accomplish the intent of the Parties as originally set forth in the Contract;

- 1.2.11. No failure on the part of any Party to exercise, and no delay in exercising, any right hereunder shall operate as a waiver thereof, and no single or partial exercise of any such right shall preclude any other or further exercise thereof or the exercise of any other right.
- 1.2.12. References to recitals, Articles or schedules in the Contract shall, except where the context otherwise requires, be deemed to be references to recitals, Articles and schedules of or to the Contract; and
- 1.2.13. In case the day on or by which any thing is to be done is not a Business Day, that thing must be done on or by the immediately occurring next Business Day

2. PRIORITY OF CONTRACT DOCUMENTS

The several documents forming the Agreement are to be taken as mutually explanatory of one another, but in case of ambiguities or discrepancies, the same shall be explained and adjusted by the company, who shall, accordingly, issue suitable instructions thereon to the Contractor. In such event, unless otherwise provided in the agreement or explained by way of instructions by the company, as mentioned above, the priority of the documents forming the Agreement shall be as follows:

- i) Contract Agreement/Work Order.
 - (a) Special Conditions of Contract
 - (b) General Conditions of Contract
- (ii) The Letter of Acceptance/ Intent
- (iii) Agreed Minutes of the Tender Negotiation Meetings
- (iv) Agreed Minutes of the Tender Technical Meetings
- (v) The Priced Bill of Quantities
- (vi) The Technical Specifications / Scope of work
- (vii) The Tender document, including all Appendices and/or Addenda, Corrigendum the latest taking precedence.

In the event of any conflict between the above-mentioned documents, the more stringent requirement or conditions which shall be favourable to the company shall govern and the decision of company/BYPL shall be final and binding upon the parties.

3. AMENDMENT

Any modification, amendment or other change to the Agreement shall be affected only by a written instrument signed by the authorized representatives of both, the Company and the Contractor.

4. LANGUAGE AND MEASUREMENT

All correspondence and documents relating to this order placed on the Contractor shall be written in English language. Metric System shall be followed for all dimension on, units etc.

5. EXAMINATION OF SITE & LOCAL CONDITIONS

The contractor is deemed to have visited all the sites that comes under Company's licensed area under the Contract and therefore, ascertained all site conditions and information pertaining to the services to be provided under this contract. The company shall not accept any claim whatsoever arising out of the difficulties at site/terrain/local conditions, if any.

6. TAXES & DUTIES

- (i) Prices shall be inclusive of all taxes and duties including labour cess (except GST). However, Income Tax(TDS) as per applicable rate in accordance with Income Tax Act will be deducted from contractor's bills.
- (ii) GST at actual shall be paid extra on submission of GST Registration and self-declaration on Contractor's letter head stating that you have deposited/or will deposit the Tax as per the applicable GST laws. Contractor shall furnish its GST registration number.
- (iii) Any statutory variations i.e. increase/decrease in Taxes / Duties introduced by central Govt. / State Govt. shall be reimbursed/recovered to/from Contractor against documentary evidence and proof.
- (iv) As Per Notification No. 39/2021 # Central Tax dated 21st December, 2021 w.e.f 01/01/2022 registered person (i.e., Recipient/Purchaser) can avail tax credit on those invoices only which have been reflected in GSTR 2A or GSTR2B (it means 100% matching of invoice is required). Also, GST has to be deposited by Supplier/Contractor by filing of GSTR- 1 and GSTR-3B.
- (v) In view of above, if the same is not complied with by the supplier/Contractor and the Recipient/Purchaser is not in position to avail / utilize Input Tax Credit due to non-compliance or non-filing of GSTR-1 and GSTR-3B for the month/quarter (as applicable) in which the supply was made, then Recipient/Purchaser has right to hold 100% GST amount from next payment due of the subsequent month till the time default is not cured.
- (vi) For releasing of the payment kept on hold on account of non-compliance of GST Act, supplier/Contractor shall submit payment proof i.e. GST Portal screenshot reflecting name of Recipient/Purchaser along with GSTR-1 and GSTR-3B for month/quarter (as applicable) in which the same has been discharged. Payment shall not be released, till the time necessary proof showing the discharge of GST liabilities by the contractors for the period in default are submitted to the Company.
- (vii) Further, the recipient/purchaser shall also be entitled to recover any financial loss suffered by the Company (including tax, interest, penalty and lapse of input credit) due to non-compliance or non-filing of GSTR-1 and GSTR-3B by the supplier/Contractor.
- (viii) In case where delivery of goods is being made on FOR site basis, the Supplier/Contractor is responsible to comply with rules applicable for E-way bill. Any

violation in provision of E-way Bill will attract penalty and seizure of Transit Material. Any Penalty and Pre-Deposit due to violation of rules/provision shall be paid and borne by Supplier/Contractor. Also, Supplier/Contractor is responsible to get the goods released from the concerned authority. Delay in supply due to seizure of goods shall attract liquidated damages as per Order / Agreement provisions.

7. PAYMENT

- 7.1. Subject to the Contractor fulfilling its obligations under the Contract, the Company shall pay to the Contractor the Contract Value as per the terms of the Contract. The Company shall, notwithstanding any provision to the contrary included in the Contract, be entitled to deduct from and/or set off against any amount due or become due, whether related to this contract or other contracts awarded to contractor. However, any and all amounts which the Contractor is liable to pay to the Company, the contractor shall make payment as per the agreed schedule to avoid any set off / deductions.
- 7.2. Subject to the provisions of the Contract, the Contractor shall submit to the Company, monthly on-account Running Bills on or before the 10th of every month in respect of the Services executed by the Contractor in the preceding month. If the Contractor fails to submit any Tax Invoice (Running Bill) by the 10th of any month, then the Company shall have the right to consider such Tax Invoice (Running Bill) only in the immediately succeeding month. The Running Bills shall only be for such Services, as, in the opinion of the Company, the Contractor has executed in accordance with the Contract, based on the certification of Services by the Company in accordance with the Contract. Within 30 days from the receipt of correct Running Bill along with relevant documents, payment shall be released to Contractor's designated bank account through RTGS /online payment as per payment terms under the Contract.
- 7.3. The Running Bills to be submitted by the Contractor shall be in the format approved by the Company. Each Running Bill submitted by the Contractor under the Contract shall be supported with relevant documents as instructed by the Company from time to time. On receipt of the Running Bill by the Company, the Company shall scrutinize the same to check for any errors and to verify that the amount claimed under the Running Bill is in conformity with the Contract. The Running Bill shall be payable only after certification of Service(s) and approval of the Running Bill for payment by the Company.
- 7.4. All monitoring, measurement, billing & payment processes shall be on IT enabled platform of BYPL as per Company's guidelines issued from time to time and bidders to ensure adherence.
- 7.5. Contractor shall upload correct monthly running bills along with all supporting documents in online BTS (Bill Tracking Systems) software or any other IT enabled platform of BYPL as per Company's guidelines issued from time to time for certification / approval purpose and bidders to ensure adherence.
- 7.6. The Contractor shall ensure that their billing documents support cost / expenses booking at Divisional level / Sub Divisional level as required by the Company.

8. TAX INVOICE SUBMISSION PROCEDURE AND CERTIFICATION

- 8.1. Tax Invoice shall be submitted to the Company for certification. Contractor must pay due attention for submission of Tax Invoice in time and along with relevant Documents to Company.
- 8.2. Tax Invoice shall be certified by Company after verifying relevant original Documents submitted by Contractor. If original Document associated with Tax Invoice is misplaced or lost during transit or for any genuine reason(s) attributable to Contractor, the reason(s) should be informed to Company in writing in stipulated period as instructed by Company. A true copy of certified Document with an indemnity bond or Bank Guarantee, as the case may be, must be submitted in the format provided by the Company.
- 8.3. Incomplete Tax Invoice will not be considered for processing of payments in terms of the Contract. Company reserves right to recover payable amount or part of Tax Invoice from available financial security or other dues of the contractor with the Company. Contractor shall be paid in terms of the Contract based on certification of Tax Invoice along with associated relevant Document(s) by the Company only.

9. TIME ESSENCE OF CONTRACT

Time is the essence of the contract and the contractor shall be responsible for performance of his works in accordance with the specified schedule. If at any time, the contractor is falling behind the schedule for reasons attributable to him, he shall take necessary action to make good for such delays by increasing his work force or by working overtime or otherwise to accelerate the progress of the work and to comply with schedule timelines and shall communicate such actions in writing to the company, to the satisfaction of the Company that his action will compensate for the delays. The contractor shall not be allowed any extra compensation for such actions.

Time shall be the essence of the Contractor. Contractor shall complete his work in accordance with the specified time-lines/ Schedules as per the terms of the contract or as may be instructed by the Company from time to time.

10. LIQUIDATED DAMAGE

- 10.1 Contractor shall ensure that the work under the agreement is carried out in accordance with the terms and conditions of the agreement. The decision of the authorized personnel / Engineer – in- charge as regards performance of the contract will be final and binding. If the work under the agreement is not carried out to the satisfaction of the authorized personnel/Engineer – in- charge of BYPL including events of delay for reasons attributable to the Contractor, the Contractor shall be liable to pay and/or reimburse to the Company a sum:
 - a) Equivalent to charges for completion /rectification of work plus 30% overhead charges, which will be recovered from the Contractor's invoice/outstanding payment/CPBG;
 - b) Equivalent to the penalties defined in various clauses of tender/contract.

10.2 The parties agree that the above amounts, including the amounts set out in the provisions relating to the penalty, are a reasonable estimate of the additional expenses required to be incurred by the Company due to the breach by the Contractor of the terms and conditions of this agreement. The Company shall be entitled to set off the entire amounts due from the Contractor against the amount payable by Company to the Contractor and CPBG.

11. NOT USED

12. OPENING OF SITE OFFICE:

The Contractor shall also open and maintain a site office in the area and depute its authorized representative there.

13. ACCESS TO THE SITE

13.1 The Company shall provide to Contractor the right of access to the Site progressively for the Execution of the Works. The Contractor acknowledges that its access to the Site shall not be exclusive to the Contractor but subject to the restrictions as contained in the Contract as well as the following:

- (a) Any public passage or right existing over any part of the Site from time to time;
- (b) The rights and obligations of persons or authorities under any Applicable Laws; and
- (c) The rights of the Company's Representative, Consultants or any other representative of the Owner or any statutory authorities to have access to the Site for inspection of the Works

13.2 If the Contractor foresees any delay in the Execution of the Works due to failure on the part of the Company to provide right of access to the Site, the Contractor shall immediately give written notice to the Company's Representative substantiating its claim for any delay in the execution of the works due to delay in providing the Site. After receipt of such notice, the Company's Representative shall determine extension of time, if any, to be granted to the Contractor and notify the Contractor accordingly. The Contractor acknowledges and agrees that it shall not be entitled to any monetary claim under any circumstances whatsoever due to any delay in handing over of the Site by the Company.

13.3 The Contractor shall not demolish, remove or alter any structures or other facilities on the Site without the prior written approval of the Company's Representative. The Contractor shall further ensure that all garbage resulting from the Execution of the Works is removed or disposed of, in accordance with Applicable Laws.

14. INSPECTION & QUALITY CONTROL

Inspection shall be performed by BYPL or its appointed authorized inspection agency. The contractor at his sole expenses shall correct defective works. Such rectification needs to be done / completed within the timelines specified by BYPL.

15. DEMOBILISATION/ HANDOVER ON CONTRACT COMPLETION

- 15.1 The contractor shall ensure that all the premises/equipment/services are in good working condition and are with full configuration while handing over back to the Company/new Contractor at the end of the contract.
- 15.2 The demobilization/ handover period will be a period of up to 30 days starting from the date of expiry of the contract. The Contractor shall have to complete the demobilization process including closing all pending calls, and handing over all site-related information to the new Contractor/BYPL during this period.
- 15.3 Within 30 days of the expiry of the contract, the Contractor's representative and BYPL's representatives or the new Contractor may carry out a Joint survey/physical inspection to identify the status of the premises/equipment/services at their locations. If any of the premises/equipment/services are found non-working/ irreparable / unsatisfactory, it is the responsibility of the contractor to make the same good as part of the existing contract.
- 15.4 No payments shall be admissible for the demobilization period/activities.
- 15.5 In case the Contractor is not able to close the pending work as identified in Joint survey/physical inspection during the demobilization period, BYPL at its sole discretion can get the work done / Services rendered/ equipment restored/ repaired/substituted by new Contractor/the third party at the risk and cost of the Contractor and the same will be deducted/recovered from the bills of the contractor or the security amount , CPBG , retention amount or otherwise as per terms of the contract and no claim from the Contractor's side , of any nature, including the claim citing the award of work to third party and consequences thereof, shall not be maintainable.
- 15.6 Payments for the last month shall be cleared only after all the pending works have been closed successfully as indicated above.
- 15.7 Ceiling on deductions/penalty stipulated in this contract, if any, shall not be applicable on deductions stipulated herein during demobilization/ handover on contract completion.

16. REPORTS AND INFORMATION

The Contractor shall be obliged to submit or furnish to Company, all or any information as desired by company, in the form of a report or otherwise. The report may be required at regular interval as specified/required by company. The information shall be provided in a format to be specified by the company to the Contractor. However, company, reserves the right to revise this format which would be communicated to the Contractor and it shall be valid and binding obligation on the Contractor to submit the desired information in the revised format.

17. STATUTORY OBLIGATIONS

The Contractor shall ensure the due compliance of all the applicable statutory acts, including but not limited to the following acts, where special attention of the Contractor is required to be drawn towards the compliance of provision (along with the latest amendments/additions) including any statutory approval required from the Central/State Governments, Ministry of Labour.

- The Child Labour (Prohibition and Regulation) Act, 1986.
- The Agreement Labour (Regulation and Abolition) Act, 1970.
- The Employee's Pension Scheme, 1995.
- The Employee's Provident Funds and miscellaneous provisions Act, 1952.
- The Employees State Insurance Act, 1948.
- The Industrial Disputes Act, 1947.
- The Maternity Benefit Act 1961.
- The Minimum Wages Act, 1948.
- The Payment of Bonus Act, 1965.
- The Payment of Gratuity Act, 1972.
- The payment of Wages Act, 1936.
- The Delhi Shops & Establishment Act, 1954.
- The Workmen's Compensation Act. 1923.
- The Company's Liability Act, 1938.
- The Sexual Harassment of Women at Workplace (Prevention, Prohibition and Redressal) Act, 2013
- The Delhi Preservation of Trees Act 1994
- The private security agencies (regulation) Act, 2005 (PSARA – Delhi State)

Further the Contractor shall be liable to comply with all the amendment in existing acts / upcoming new comprehensive labour acts/codes related to applicable labour laws.

The Contractor shall, prior to commencement of the jobs under this agreement, furnish to the Company the Registration No and Codes of permanent Provident Fund and ESI of its employees.

Contractor shall bear the entire responsibility, liability and risk relating to coverage of its workforce under different statutory regulations including Workmen's Compensation Act, ESI Act, Factories Act 1948, the Agreement Labour (Regulation and Abolition) Act 1970, as amended from time to time, and any other relevant laws/regulations as the case may be. Contractor shall also be solely responsible for the payment of all benefits such as Provident Fund, Bonus, Retrenchment Compensation, leave etc. applicable as per the various statutory laws/regulations and shall keep the Company indemnified in this regard against any claim. The Company shall be entitled to deduct from any money due to or

become due to Contractor, any money paid or payable by way of compensation as aforesaid or cost or expenses in connection with any claims thereto and Contractor shall abide by the decision of the Company as regards the sum payable by Contractor under the provisions of this clause

The Contractor shall obtain all registration/permissions licenses etc., which are/may be required under any labour or other legislations for providing the services under this Agreement.

Contractor shall take insurance policy under the Workmen Compensation Act to cover workers, not covered under ESI Act 1948, engaged by it and Accident Liability Insurance for its employees for payment of compensation on account of injury, fatal or otherwise due to accident during service. Copies of these insurance policies will be submitted to company for reference and records and these insurance policies shall be kept valid at all times.

In case it is desired by any Labour authorities to produce the records with respect to salary/ PF/ESI/EDIL/Bonus etc., the said record/register will be made available by the Contractor.

The contractor shall follow all law of the land and prevailing orders issued by various Govt. Departments like Dept of Power / DERC/ NGT/Dept. of Forest/ Dept. of Environment / DPCB / CPCB/ Court orders etc.

18. PENALTY FOR NON-COMPLIANCE OF STATUTORY REGULATIONS

If any non-compliance of any Statutory Obligation is observed then an amount equivalent to 1.5 times of the value of the non-compliance will be retained from outstanding (monthly) payment bill, however; if non-compliance is continued, penalty will be levied as follows:

- a. Retained amount will be converted into penalty if Non-compliances are not closed within 60 days
- b. Termination of agreement in case non-compliances are not cleared after show cause in writing.
- c. The imposition of the penalty is without prejudice to the BYPL's right to terminate the Contract. The closure of the work and final settlement of the contract order shall be effected only after issuance of NOC by BYPL.

19. PENALTY FOR MISCONDUCT/FAILURE IN PERFORMANCE OF TASK UNDER AGREEMENT

19.1 The Contractor and its manpower shall adhere all code of conduct/Schedule/SOP/Instructions associated with the task to be performed under the agreement.

19.2 During the period of validity/execution of task under agreement, the behavior of manpower deputed by Contractor shall be entirely professional and shall not commit any misconduct.

19.2.1 Misconduct shall refer to the following:

- a. Interaction with the customer in a non-professional way, including any form of verbal/physical abuse to customer or misuse/damage/tempering of premises and/or meter.

- b. Any form of harassment to customer i.e. asking for bribes, reaching customer premises outside the defined working hours, asking the customer for any favours etc.
- c. Additional interaction with customer not under purview of task to be performed under agreement.
- d. Provide other customer services with or without a charge unless directed by BYPL.
- e. Accessing BYPL's IT Infrastructure within data centre or anywhere else, in BYPL premises.
- f. -

19.3 BYPL shall conduct audit and quality checks on the activities to be performed by Contractor and/or the personnel deputed by Contractor under Agreement on a periodic basis, to ascertain the overall quality and performance of field activities.

19.3.1 Any complaints received by BYPL either directly from the customer or observations through audit or any other sources shall be reviewed by BYPL. The decision of the committee on the final action on Contractor shall be binding.

19.4 PENALTY FOR MISCONDUCT

(a) The penalty to be imposed in case of misconduct shall be as follows:
In case of any misconduct as defined above, a penalty of Rs 5000/- per incident shall be levied.

(b) In case of multiple incidences of Misconduct:

- 1) 4 complaints per annum OR
- 2) more than 1 complaint in a quarter

An additional penalty of Rs 20,000/- shall be levied and possible termination of the contract.

19.5 The person responsible for such incidence of misconduct must be immediately removed by Contractor from Company's services under the contract and should also never be deployed for providing any other services to the Company. If needed contractor shall file police FIR against such person

19.6 The Contractor shall collect the following documents from the manpower deputed under this agreement, within two weeks of mobilization and shall deposit the same with BYPL as & when demanded, as follows:

- (i) Educational Qualification Certificate: Certificate and mark-sheet of all manpower demonstrating the highest educational qualification of all personnel, making them competent for the task assigned.
- (ii) Permanent Address Proof: Supporting document for permanent address proof of all personnel.
- (iii) Identity Proof: Copy of PAN/Aadhar card should be submitted as identity proof for all personnel.

19.7 Contractor shall deploy the manpower in mutual consultation with BYPL. BYPL reserves the right to reject deployed manpower, in case the same is not found suitable.

- 19.8 The Contractor shall conduct relevant background checks and prepare Background Reports through an authorized agency of all manpower deployed for the performance of task under agreement in BYPL within one month of deployment.
- 19.9 Such reports shall be shared with BYPL as requested. Contractor shall submit an Affidavit clearly stating that back-ground check for all personnel is complete and back-ground reports have been prepared to this effect within one month of deployment.

20. STATUTORY PERMISSION/ APPROVALS

- 20.1. The Contractor shall take all steps as may be necessary to comply with the various applicable laws/rules including the provisions of agreement labour (Regulation & Abolition Act) 1970 as amended, minimum wages Act, 1948, Workmen Compensation Act, ESI Act, PF Act, Bonus Act and all other applicable laws and rules framed there under including any other statutory compliance/approval required from the Central/State Govt., Ministry of Labour.
- 20.2. The Contractor must also submit the following before award of Work Order under agreement and these shall be renewed time to time:
- a) Certificate of registration under Contract labour (R & A) Act 1970.
 - b) PF Code No. and all employees to have PF A/c No. under PF Act, 1952.
 - c) All employees to have a temporary or permanent ESI Card as per ESI Act.
 - d) ESI Registration No.
 - e) GST registration number
 - f) PAN No.
 - g) Electrical License as applicable
 - f) Labour License under Labour Act (R & A) Act 1970. A copy of Labour License shall be deposited by Contractor with all Engineer-in-charge responsible for execution of the job before start of the work by the contractor, as per guidelines of HR department.)
- 20.3. The Contractor must follow/adhere/perform the following task:
- (a) To take Third party Insurance Policy before start of work.
 - (b) To follow Minimum Wages Act prevailing in the state.
 - (c) Salary / Wages to be distributed not later than 7th of each month.
 - (d) To maintain Wage- cum - Attendance Register.
 - (e) To maintain First Aid Box at Site.
 - (f) To Submit Latest P.F. and E.S.I. challans pertaining to the period in which work was undertaken along with a certificate mentioning that P.F. and E.S.I. applicable to all the employees has been deducted and deposited with the Authorities within the time limits specified under the respective Acts.

- (g) To frame and adhere the Workmen Compensation Policy in compliance with the law.
- (h) To obtain Labour license before start of work.
- (i) Registration of Contractors & Contractual Employees under Building & other Construction Worker Welfare Cess Act 1996 & The Building & \ other Construction Workers (Regulation of Employment & Conditions of services) Act 1996, as applicable
- (j) Registration under “The Delhi Building and other Construction Worker (Regulation of Employment and Conditions of Services) Rules 2002(B.O.C.W.)”, as applicable

Before commencing the work, it would be mandatory for the Contractor to furnish the Company the permanent PF code no and ESI of the employees.

- 20.4. Contractor ensures that Manpower deployed at the site must adhere to terms & conditions as set out in the Contract.
- 20.5. The Contractor shall give a written declaration / undertaking on or before 15th of the following month that he has complied with the following:
 - a) Has paid minimum wages to his manpower along with its proof.
 - b) Deduct and deposited ESI/PF contribution. Copy of the same shall be submitted
- 20.6. Contractor shall comply with all the amendments to existing acts, upcoming new comprehensive labour acts related to applicable labour law, wage code etc

21. PERMITS, LICENSES&APPROVALS

- 21.1. It shall be the Contractor’s exclusive responsibility to obtain all requisite approvals, permits or licenses required for the performance of the Services. However, upon the request of the Contractor, the Company may, where it is necessary to do so, provide reasonable assistance to the Contractor, at the risk and cost of the Contractor, in applying for and obtaining such permits, licenses or approvals. Any delay in obtaining any such permits, licenses and approvals shall not relieve the Contractor from any of its obligations under the Contract.
- 21.2. The cost of obtaining the above mentioned permits, approvals and licenses and follow-up of the applications for such permits, approvals and license shall be borne by the Contractor.
- 21.3. It shall also be the Contractor’s exclusive responsibility to obtain those requisite approvals, permits or licenses required for the performance of the Services which

needs to be obtained by the Company. However, the cost of obtaining such permits, approvals and licenses shall be borne by the Company. Company shall provide reasonable assistance to the Contractor in applying for and obtaining such permits, licenses or approvals. Any delay in obtaining any such permits, licenses and approvals shall not relieve the Contractor from any of its obligations under the Contract.

22. REPRESENTATION, WARRANTIES AND GUARANTEES

The Contractor hereby represents warrants and guarantees that:

- 22.1. It is a legally recognized entity under the laws of India;
- 22.2. The Agreement contains valid and binding obligations and is enforceable in accordance with the terms hereof;
- 22.3. It has studied the technical feasibility, Site conditions and other prevailing conditions and all other operational details and based on these studies carried out, has agreed to provide to the Company the services as contemplated in this Agreement;
- 22.4. It has appraised itself of all applicable rules and regulations, and shall at all times comply with such rules and regulations;
- 22.5. It shall procure vehicles and hire manpower suitable for the purposes of rendering services as contemplated in this agreement;
- 22.6. The Services would be conducted in a safe and efficient manner at the Site and at all times in compliance with Good Industry Practices and requirements of the Company, and in any event, in accordance to this Work Order/agreement;
- 22.7. It shall procure all consents, licenses, permits, approvals and certificates and authorizations as may be required from any governmental authority for the performance of services at the Site;
- 22.8. It shall duly pay the duties, taxes and levies as are set out in this agreement or otherwise, which are to be paid by the Contractor;
- 22.9. There is no action, suit or proceeding, at law or in equity, or to the best of knowledge of Contractor, any official investigation before or by any governmental authority, arbitration tribunal or other body pending or, to the best of its knowledge, threatened against or affecting it or any of its property, rights or assets, which could reasonably be expected to have material adverse effect on its ability to perform its obligations under this Agreement or on the validity or enforceability of this agreement.

23. EVENTS OF DEFAULTS

Company may, without prejudice to any of its other rights or remedies under the Contract or in law, terminate the whole or any part of this Contract by giving written notice to the Contractor, if in the opinion of Company, contractor has neglected to proceed with the Contracts with due diligence or commits a breach of any of the provisions of this Contract including but not limited to any of the following cases:

- 23.1. Failing to complete execution of Contract as per the terms and conditions specified in the Contract.
- 23.2. Failing to complete Contracts in accordance with the approved schedule of Contract.
- 23.3. Failing to comply with any reasonable instructions or orders issued by Company in connection with the Contract.
- 23.4. Failing to comply with any of the terms or conditions of this Contract.
- 23.5. In the event Company terminates this Contract, in whole or in part, on the occurrence of any event of default, Company reserves the right to engage any other vendor or agency to complete the Contract or any part thereof, and in addition to any other right Company may have under the Contract or in law including without limitation, including the right to penalize for delay under clause "Liquidated Damage" of this Contract, the contractor shall be liable to Company for any additional costs that may be suffered/borne by Company for the execution of the Contract.
- 23.6. Failure on the part of the Contractor to maintain its confidentiality obligations and or compromising its integrity, which are required to be of highest standards, in so far as the present scope of work is concerned.

24. RISK & COST

If the Contractor fails to execute the work as per specification/Agreement/as per the direction of Engineer-in-charge within the scheduled period and/or even after the extended period, the company shall be having the right to cancel/terminate the agreement and the company reserves the right to get the work executed from any other source at the Risk & Cost of the Contractor. The Extra Expenditure so incurred alongwith overhead charges @15% shall be debited to/recovered from the Contractor.

25. LIMITATION OF LIABILITY

- 25.1. The Contractor's liability (except Third Party Liability; covered under the agreement and addendums thereto) for all damages, losses, acts or omissions, howsoever occasioned, shall not, at any time exceed an amount equivalent to Contract Value.
- 25.2. Notwithstanding anything stated in the agreement, the limitation of Liability shall not be available/applicable in case of wilful default/breach/negligent act/misconduct on the part of the Contractor and/or its employees.

26. TERMINATION

26.1. TERMINATION BY COMPANY FOR NON PERFORMANCE

During the course of the execution, if at any time the Company observe and forms an opinion that the work under the order is not being performed satisfactory and the performance of the Contractor not found satisfactory, the Company reserves its right to cancel/ terminate this Agreement giving minimum 30 days' notice without assigning any reason and the Company will recover all damages including losses occurred due to loss of time from the Contractor. After termination of the agreement, the Contractor shall

immediately stop all activities related to the work terminated. This is without prejudice to other rights under the terms of contract. The Contractor shall hand over the Company all drawing/documents prepared for this contract up to the date of cancellation of order.

26.2. PREMATURE TERMINATION

The order can be terminated by the Company before the expiry of its term under the following conditions:

- (i) The Contractor repudiates this order or otherwise evidences intention not to be bound by this order;
- (ii) The Contractor assigns, mortgages, or charges or purports to assign, mortgage, or charge any of its obligations or rights in contravention to the provisions of this order; or, transfers or negates any of its obligations in contravention to the provisions of this order.
- (iii) The Contractor breaches the Secrecy/Non-disclosure Clause/Confidentiality obligations.
- (iv) If at any stage during the tenure of the work order, Contractor is found to be involved or indulging or even attempting illegal, unlawful action or activities or some fraudulent or even trying to take or ask bribe from any customer or to give bribe official/staff or misuse or abuse any meter or property of the Company.
- (v) The Company shall be entitled to deduct from any money due or to become due to the Contractor, money paid or payable by way of compensation as aforesaid or cost or expenses in connection with any claims thereto. The Contractor shall abide by the decision of the Company as to the amount payable by the Contractor under the provision of this clause.

26.3. TERMINATION BY COMPANY FOR CONVENIENCE

The Company shall, in addition to any other right enabling it to terminate the Contract, have the right to terminate the Contract at any time without assigning any reason, by giving a written notice of minimum 30 days to the Contractor. The Contract shall stand terminated on the date as per the notice but such termination shall be without prejudice to the rights of the Parties accrued on and before the date of termination.

27. GOVERNING LAW AND ARBITRATION

- 27.1. Governing Law: This Work Order/Agreement shall be governed by the laws of India and each party submits to the exclusive jurisdiction of the courts in New Delhi.
- 27.2. Dispute Resolution Mechanism. All disputes and differences arising out of or in connection with this Agreement shall be resolved amicably by mutual discussion within 30 days. If the dispute cannot be resolved by mutual discussions and agreement, the parties will take such dispute to an arbitral panel comprising Sole Arbitrator jointly appointed by the parties to agreement.
- 27.3. In the event parties fail to appoint the sole arbitrator within 30 days from the date of request made by party, the Sole Arbitrator shall be appointed as per the provisions of The Arbitration and Conciliation Act 1996 as amended upto date. The arbitration shall be conducted in New Delhi in accordance with the provisions of the Arbitration and Conciliation Act 1996. The award of the arbitral panel shall be final and binding on all

parties. The arbitration proceedings shall be conducted in English. The venue and seat of Arbitration shall be in Delhi Only. The cost of arbitration shall be shared equally between the parties unless otherwise directed by the Arbitrator.

28. FORCE MAJEURE

28.1. General

An "Event of Force Majeure" shall mean any event or circumstance not within the reasonable control, of the Party affected, but only if and to the extent that:

- (i) Such event or circumstance, despite the exercise of reasonable diligence, could not have been prevented, avoided or reasonably foreseen by such Party;
- (ii) Such event or circumstance materially and adversely affects the ability of the affected Party to perform its obligations under this agreement, and the affected Party has taken all reasonable precautions, due care and reasonable alternative measures in order to prevent or avoid the effect of such event on the affected party's ability to perform its obligations under this Agreement and to mitigate the consequences thereof. For the avoidance of doubt, if such event or circumstance would not have materially and adversely affected the performance of the affected party had such affected party followed good industry practice, such event or circumstance shall not constitute force majeure.
- (iii) Such event is not the direct or indirect result of the failure of such Party to perform any of its obligations under this Agreement; and
- (iv) Such Party has given the other Party prompt notice describing such events, the effect thereof and the actions being taken in order to comply the relevant clause.

28.2. Specific Events of Force Majeure

Subject to the provisions of the agreement, Events of Force Majeure shall include only the following to the extent that they or their consequences satisfy the above requirements:

- (i) The following events and circumstances:
 - a) Effect of any natural element or other acts of God, including but not limited to storm, flood, earthquake, lightning, cyclone, landslides or other natural disasters, and
 - b) Explosions or fires or flood
- (ii) Public disorder, insurrection, rebellion, sabotage, riots or violent demonstrations of a local character;
- (iii) Declaration of the Site as war zone.
- (iv) Any order, regulation, directive, requirement from any Governmental, legislative, executive or judicial authority.

28.3. Notice of Events of Force Majeure

If a force majeure event prevents a party from performing any obligations under the Agreement in part or in full, that party shall:

- (i) Immediately notify the other party in writing of the force majeure events within 2 working days of the occurrence of the force majeure event
- (ii) Be entitled to suspend performance of the obligation under the Agreement which is affected by force majeure event for the duration of the force majeure event
- (iii) Use all reasonable efforts to resume full performance of the obligation as soon as practicable
- (iv) Keep the other party informed of all such efforts to resume full performance of the

- obligation on a regular basis
- (v) Provide prompt notice of the resumption of full performance or obligation to the other party.

28.4. Mitigation of Events of Force Majeure

The Contractor shall:

- (i) Make all reasonable efforts to prevent and reduce to a minimum and mitigate the effect of any delay occasioned by an Event of Force Majeure, including applying other ways in which to perform the agreement;
- (ii) Use its best efforts to ensure resumption of normal performance after the termination of any Event of Force Majeure and shall perform its obligations to the maximum extent practicable as agreed between the Parties; and
- (iii) Keep the Company informed at regular intervals of the circumstances concerning the event of Force Majeure, with best estimates as to its likely continuation and what measures or contingency planning it is taking to mitigate and or terminate the Event of Force Majeure.

28.5. Burden of Proof

In the event that the Parties are unable in good faith to agree that a Force Majeure event has occurred to an affected party, the parties shall resolve their dispute in accordance with the provisions of this agreement. The burden of proof as to whether or not a force majeure event has occurred shall be upon the party claiming that the force majeure event has occurred and that it is the affected party.

28.6. Termination for Certain Events of Force Majeure

If any obligation of any Party under the Agreement is or is reasonably expected to be delayed or prevented by a Force Majeure event for a continuous period of more than 1 (one) month during the Term of the Agreement, the Agreement shall be terminated at the discretion of the Company and neither Party shall be liable to the other for any consequences arising on account of such termination.

The Company reserves the right to demand the Contractor's services on holidays as well as beyond the normal working hours.

The Contractor will ensure that none of their person is engaged in any unlawful activities subversive of the Company's interest failing which suitable action may be taken against the Contractor as per the terms and condition of this order.

The Contractor shall be liable for payment of all taxes and duties as applicable, to the State/ Central Govt. or any local authority.

The Contractor's employees shall not be treated as Company's employees / persons for any purpose whatsoever & facilities/ benefits applicable to the Company's employees shall not be applicable to Contractor's employees. If due to any reasons whatsoever the

Company is made liable to meet any obligation under any of the laws & enactment etc, for any reason whatsoever the same shall be recovered from the Contractor either from the present and future amount payable to him or as per law.

29. NOTICE & COMMUNICATION

Any notice or other formal communication to be given under this agreement shall be in writing and signed by or on behalf of the party giving it and shall be sent by registered post, A.D. to the addresses of Contractor or BYPL as mentioned herein above or to any other addresses as agreed by the parties, in writing from time to time.

Any notice or other formal communication can also be sent through official e-mail ID of authorized person of Contractor or BYPL.

30. SAFETY CODE

- 30.1. The Contractor shall ensure adequate safety precautions at site, as required under the law of the land to facilitate safe working, during the execution of work under agreement/work order and shall be entirely responsible for the complete safety of their workmen as well as other workers at site and premises during performance of work under agreement.
- 30.2. The Contractor shall observe the safety requirements as laid down in the agreement and in case of sub-contract/assignment (only after written approval of company), it shall be the responsibility of Contractor that all safety requirements are followed by the employees and staff of the sub-contractor.
- 30.3. The Contractor employing two hundred employees or more, including employees deputed under agreement, shall have a safety officer in order to ensure the implementation of safety requirements of the agreement and if the Contractor having lesser number of employees, including agreement workers, shall nominate one of its employees to act as safety coordinator who shall liaise with the safety officer on matters relating to safety and his name shall be displayed on the notice board at a prominent place at the work site.
- 30.4. The Contractor shall be responsible for non-compliance of the safety measures, implications, injuries, fatalities and compensation arising out of such situations or incidents.
- 30.5. In case of any accident, the Contractor shall immediately submit a statement of the same with BYPL and the safety officer, containing the details of the accident, any injury or causalities, extent of property damage and remedial action taken to prevent recurrence and in addition, the Contractor shall submit a monthly statement of the accidents to BYPL at the end of each month.
- 30.6. The contractor / safety officer shall be responsible for providing training to all staff & workers, safety compliances, testing and fitness of all T&P , PPE, safety audit reports etc. in line with CEA norms

31. WORKMEN COMPENSATION

- 31.1. The Contactor shall take insurance policy at his own cost under the Workmen Compensation Act to cover such workers who are not covered under ESI by the Contractor however engaged to undertake the jobs covered under this order and a copy of this insurance policy will be given to Company for reference and records. This insurance policy shall be kept valid at all times. In case there are no worker involve other than those who are covered under ESI by the Contractor, the Contractor shall certify for the same.
- 31.2. The Contractor shall keep the Company indemnified at all times, against all claims of compensation under the provisions of Workmen Compensation Act 1923 as amended from time to time or any compensation payable under any other law for the time being involving workmen engaged by the Contractor in carrying out the job involved and against costs and expenses, if any, incurred by the Company in connection therewith and without prejudice to make any recovery.
- 31.3. The Company shall be entitled to deduct from any money due to or to become due to the Contractor, moneys paid or payable by way of compensation as aforesaid or cost or expenses in connection with any claims thereto and the Contractor shall abide by the decision of the Company as to the amount payable by the Contractor under the provisions of this clause.

32. THIRD PARTY INSURANCE

The Contractor shall, before the commencement of work, take a Third Party Insurance of an adequate value, at his own cost and expenses, securing all the risks/losses/damages which may be caused to any third party and/or BYPL and/or its employees/associates, because of the omission/performance of tasks by the Contractor under this agreement. The full and final settlement of claims raised by third parties shall be the sole responsibility of the Contractor without any liability to BYPL.

It is further agreed by the Contractor that in case of defect/damage to the system because of default on the part of the Contractor, the Contractor shall, at its own cost, be liable to replace/rectify the same at the earliest or make good the loss suffered by BYPL

33. HUMAN RESOURCE ISSUES

- (A) The Contractor would execute the works under agreement through its own resources.
- (B) The Contractor shall bear all expenses/cost to be incurred towards salary, allowances, perks, travelling allowances, advances, insurance, safety measures, annual increment, security, transportation, conveyance reimbursement, telephone expenses, leave pay and all other misc. expenses etc. of their employees/ workmen during the validity/tenure of the Agreement or any renewed tenure thereto. Also, the Contractor shall be solely responsible for making payment for Hospitalization, Compensation thereof in case of any accident &

injury.

- (C) The Contractor to deploy its manpower immediately for carrying out the work as specified in the tender document.
- (D) The Contractor shall ensure that there are no disputes regarding service, payment etc. of the persons engaged by it, anytime during the tenure/validity of the contract. At no point of time during the tenure/validity of contract, the Contractor's employees shall insist upon the Company for employment, wages, and allowances or any other related matter, payment etc.
- (E) The Contractor shall not deploy the manpower below the age of 18 years or above the age of 58.
- (F) The Contractor shall not deploy the female manpower between 7 PM to 6 AM.
- (G) The Contractor shall be directly responsible for any / all disputes arising between Contractor and its persons and keep the Company indemnified against all losses, damages and claims arising thereof. The Contractor shall resolve all disputes of its manpower. All the legal dues of the manpower of Contractor is to be paid on or before due date as per applicable laws or within 8 days from date of the termination of manpower.
- (H) All safety wears required for the Contractor's manpower during the execution of work must be provided by the Contractor at its own cost and the Contractor shall ensure that its employees regularly use such safety gears.
- (I) The Contractor shall be responsible for discipline of its manpower and shall ensure that the personnel deputed should adhere to the disciplinary procedure set by the Company. The Contractor shall ensure that none of its associate/personnel is engaged in any unlawful activities or any other activity subversive of the Company's interest, failing which the same shall be termed as breach of the terms of agreement and annexures thereto and suitable action may be taken against the Contractor as per the terms & conditions of the Agreement. The Contractor will ensure that none of the manpower engaged by it will demonstrate before the offices of the Company in any manner whatsoever. In case any of the manpower engaged by Contractor is found indulging in such activities, the same shall be termed as breach of the terms of agreement and annexure thereto and the Contractor will take suitable action against such of their employees and submit the ATR with company.
- (J) The Contractor shall ensure compliance with minimum wage requirements of the correct category and shall ensure the following:
 - (a) Timely payment of minimum wages to deployed manpower as per the rate notified from time to time by the Government of National Capital Territory of Delhi.
 - (b) Compliance with all other relevant PF, ESI, Insurance and other laws as applicable per statute.
 - (c) To retain Challans/Receipt issued by Statutory Authorities like Regional Provident Fund Commissioner (RPFC)/including its own Pension Provident Fund Trust for previous month & proof of payment towards compliance of other statutory provisions like E.S.I., GST etc.
 - (d) Contractor will also produce challan/receipt with respect to payment of GST as a proof for such statutory payment.

- (K) Contractor shall comply with provisions of the Payment of Wages Act 1936, Minimum wages Act-1948, Employee's Provident Fund & Miscellaneous Provision Act 1952, ESI Act 1948, Company's Liability Act 1936, Industrial Dispute Act 1947, Maternity Benefit Act 1961, Contract Labour (Regulations & abolition) Act 1970, Delhi Shops & Establishment Act or any modification thereof, THE SEXUAL HARASSMENT OF WOMEN AT WORKPLACE (PREVENTION, PROHIBITION AND REDRESSAL) ACT, 2013 or any other Act relating to rules made hereunder from time to time. For the said purpose the Contractor shall get itself covered under the Employee's Provident Fund & Miscellaneous provision Fund 1952 & ESI directly with the appropriate Regional Provident Fund Commissioner, if not done so far and shall intimate to the Company the Code No. allotted by the RPFC & ESI Authorities within one month from the date of commencement of the work under agreement.
- (L) Contractor shall organize periodic awareness session on POSH, 2013 and strict compliance to POSH, 2013.
- (M) Contractor shall have a detailed HR policy for retirement, training, safety, job suitability, health etc. for its employees. Further the Contractor shall have proper grievance redressal process for addressing HR issues raised by its employees.
- (N) -

34. DEPLOYMENT OF RESOURCES

- 34.1. -
- 34.2. The contractor shall deploy adequate resources for the smooth execution of work assigned to them. The contractor shall provide complete details including name, address, and Aadhar Card number of resource deployed.
- 34.3. The contractor shall deploy qualified & experienced resources comprising engineers, supervisors, diploma holders, skilled, semi-skilled & unskilled staff in accordance with the requirements of electricity rules, safety laws and other applicable regulatory laws. The contractor shall also ensure to meet the requirements of performance standards as mentioned in this document. If at any stage, the Company/Engineer In-Charge finds the resources not suitable or not up to the mark, the Contractor shall deploy the alternate resources immediately.
- 34.4. Distribution of electricity is an essential service as well as a public utility service. It is imperative to secure the electric network of our license area so that uninterrupted distribution of power supply to essential services like Delhi Metro, Police, hospitals, etc. is maintained. Proper security measures are essential due to the extremely sensitive and critical nature of these services. Therefore, Contractors shall be responsible for maintaining Personal Identification Data of all staff deployed by him at our premises in electronic or any other form as prescribed by the company. In addition to this, the Contractor shall also submit a record of his deployment in various locations to BYPL on a daily basis if required by the Divisional In-charge.

- 34.5. The resource deployed by the contractor shall exercise highest level of integrity at work place and shall not involve in any type of malpractice. In case any resource of the contractor is found involved in any malpractice, the contractor shall indemnify the company for the loss incurred by the company on account of such malpractice/misconduct. Since this scope of work and the assistance contemplated under the present contract or in the nature of statutory assistance towards preventing the theft of electricity under the provisions of the electricity act 2003 the integrity levels of the Contractor and /or the agency which is awarded the contract is expected to be of the highest standards.
- 34.6. In case the contractor or the resource deployed by him unable to execute the work assigned to it as per satisfaction of the company or the workmen of the Contractor refuses to work, going on strike or for any other reason likely to lead to loss of productivity, the company shall have right of engaging any other agency or resorting to any other suitable means without giving any reason and to recover the cost incurred out of the amount payable or become due to the contractor.

35. REPLACEMENT OF RESOURCE(S)

- 35.1. Should the Company consider at its sole judgment that the persons deployed by the Contractor are not suitable for the job for whatsoever reason, the Company will have the option either (i) to seek prompt replacement deputing the other person at the cost of Contractor or (ii) to terminate this work order/agreement in part or as a whole.
- 35.2. If the Company finds any employee of the Contractor guilty of any misconduct, incompetence or negligence, the Contractor shall, if so intimated by the Company, withdraw such employee from the work of company and replace him with a qualified and competent manpower. Contractor shall keep the Company informed of all manpower replacements and all such data shall be submitted with the person nominated by Company along with personal & qualification details of such persons deputed as replacement.
- 35.3. If any employee of the Contractor found indulged in unfair practices or causing direct or indirect damage to Company's Image/Property/Revenue, immediate action shall be taken by the Contractor and the Contractor shall suitably compensate the company for all loss incurred by the Company. Contractor shall have retrenchment / removal policy in place to handle such matters.

36. CONTRACTOR'S OBLIGATIONS

A) General Obligations

- 36.1 The performance of Services as completed by the Contractor shall be wholly in accordance with the Contract and fit for the purposes for which they are intended to and as defined in the Contract. The Services shall include any Service which is necessary to satisfy the Company's requirements and as implied by the Contract.
- 36.2 The Contractor shall execute the Services within the time frame for completion as specified in the order/agreement and Scope of Work. Without prejudice to the provisions

of the Contract, before commencing the Services, the Contractor shall satisfy itself regarding the BYPL's requirements. The Contractor shall give notice to BYPL, within forty-eight (48) hours of the receipt of BYPL's requirements, of any error, fault or other defect in the BYPL's requirements or such items of reference.

- 36.3 The Contractor takes full responsibility for the adequacy and stability of Services to be performed at the Site.
- 36.4 The Contractor shall at all times endeavour to adopt best practices as is prevalent in like industry and shall always be required to achieve the desired quality and confirm to the schedule of Service(s) at no additional cost to the company/BYPL.
- 36.5 The Contractor is deemed to have satisfied itself as to the correctness and sufficiency of the BYPL's requirements and other terms of the Contract relating to its risks, liabilities and obligations set out in or implied by the Contract and all matters and things necessary for the proper performance of the Services.
- 36.6 The Contractor acknowledges the responsibility of the following during the performance of the Services:
- (a) The proper transportation of Manpower and materials upto the Site and back.
 - (b) Availability of skilled Manpower in time.
 - (c) Compliance with the HSE Conditions and adherence to Contractual terms;
 - (d) Protection of the environment and adjacent structures and taking steps for remedying any damage caused to the environment or adjacent structures during the performance of the Services by the Manpower;
- 36.7 The Contractor shall, whenever required by the BYPL, submit details of the arrangement and methods which the Contractor proposes to adopt for the performance of the Services. No alteration to these arrangements or methods shall be made without the approval of BYPL.
- 36.8 Train its Manpower in the manner as reflected in their training manual, requirements of BYPL and as per the best industry practice before the deployment at the Site. Contractor shall maintain training records. Contractor ensures to replace Manpower of same specification in order to relievier / absenteeism of Manpower. In the event of replacement of Manpower, comply with all the pre and post requisite details of deployment, including but not limited to, furnishing of all the required registrations, licenses and medical examinations at the cost of Contractor without reimbursement from Company/BYPL.
- 36.9 Contractor agrees to provide all preliminary information or data as may be required by the Company/BYPL within fifteen days of issuance of the signed LOI/Work order or as per mutually agreed timelines.
- 36.10 In case the Contractor comes across with any ambiguity and/ or discrepancy in the BYPL's requirements, it shall immediately Communicate such ambiguity and/ or discrepancy to BYPL, for seeking appropriate instructions to resolve such ambiguities and discrepancies.

- 36.11 Contractor to maintain sufficient cash flow as working capital to meet daily expenses for the Manpower.
- 36.12 Contractor to coordinate and maintain close liaison with local police and administrators. Contractor to visit Site periodically and as per specific request of Company/BYPL.
- 36.13 Notwithstanding anything contrary in the Contract, Contractor must make judicious and economical use of resources of the company/BYPL at the Site, including, but not limited to resources such as space, water and electricity. In the opinion BYPL discover the misuse of resources by the Manpower, after serving notice to the Contractor if Contractor fails to adhere to this Article, BYPL reserves right to recover a suitable amount as per BYPL discretion. BYPL decision in this regard shall be final & binding.
- 36.14 The Contractor shall not use the name of the company/BYPL in any manner for credit arrangement or otherwise and it is agreed that the company/BYPL shall not in any way be responsible for any debts, liabilities or obligations of the Contractor or its Manpower.
- 36.15 In case, if the company/BYPL is of the opinion, after due consultation with the Contractor, that extra Manpower or material / equipment is/are required for reasons of improving the quality and nature of Services at the Site, the Contractor shall arrange for the same timely at the same price specified in the Contract.
- 36.16 Contractor to ensure that the Manpower deployed should have bank account which their payment must be directly credited to their bank account by the Contractor. The Contractor shall submit the copy of its instructions to the bank to transfer the salary / wages to the account of its Manpower deputed under the contract to the company/BYPL on or before 7th day of every month for the previous month's salary transfer of individual Manpower to their bank.
- 36.17 Contractor to maintain list of Manpower in shifts and attendance muster at the Site entrance for Manpower deployed under the Contract.
- 36.18 -
- 36.19 Immediately on commencement of the Contract, Contractor shall provide complete bio data of each Manpower employed at Site and shall ensure that the information provided in respect of each Manpower is verified and correct.
- 36.20 Staff working hours will be governed by the Factories Act and Applicable Law as per State where Site is located and Manpower have been deployed.
- 36.21 Contractor must ensure that child labour are not to be deployed at the Site.
- 36.22 A detailed Site specific deployment chart shall be submitted by the Contractor to Company within 5 working days before commencement of Services.
- 36.23 Contractor must ensure to conduct at least bi-weekly surprise checking at Site where their Manpower is deployed and performing Services to ascertain performance as per Contract. Contractor shall provide adequate quick response team and surveillance team

for this purpose

- 36.24 Contractor shall develop its own network and arrangements and shall be solely responsible to recruit its own personnel for providing Services.
- 36.25 -
- 36.26 Manpower so deployed at the Site shall carry out only those Services that are stipulated under the terms of the Contract and shall not do any other job for reward or otherwise, except than those stipulated.
- 36.27 In case of accident of whatsoever nature at the Site where the Manpower is injured or dies, it would be the sole responsibility of the Contractor without any risk and cost of the BYPL.
- 36.28 Contractor to submit documents related to Manpower along with Contractor's organisation chart, authorised signatories & etc., before commencement of Services under the Contract.
- 36.29 In case death, injury to any Manpower of the Contractor, Contractor is sole responsible under Workmen Compensation Act and any other Applicable Law. Contractor must not violate any statutory provisions / Applicable Law and shall keep BYPL indemnified, in full, from any claim associated with injury/death to its employee deployed under the agreement. Contractor to compliant with all Applicable Laws. Any breach in statue / Applicable Law, BYPL reserves right to recover reasonable compensation at the discretionary of BYPL.
- 36.30 Contractor to provide master plan for deployment of Manpower and related resourced to the Company/BYPL before commencement of the Services. Along with this Contractor shall provide documentations in details covering Manpower details as requested by BYPL.

B) Compliance with Applicable Laws by Contractor

- 36.31 The Contractor shall fully familiarize itself and conform in all aspects with all Applicable Laws. The Contractor shall be bound to give all notices, file all returns, etc., required by Applicable Laws, as aforesaid and to pay all fees and charges in respect thereof. Contractor must have experienced manpower with knowledge to handle all statutory compliance related matters
- 36.32 The Contractor shall not be absolved from any of its obligations under Applicable Laws or the Contract or claim any additional amount from the Company/BYPL or seek any extension of time due to its ignorance of any Applicable Law.
- 36.33 The Contractor shall indemnify the company/BYPL against all costs, expenses, penalties and liabilities incurred/ suffered by any of the Company due to non-compliance of any Applicable Law by the Contractor in relation to the performance of the Services.
- 36.34 Contractor is required to obtain requisite license issued by the licensing officer/competent authority in the Government office before commencement of Services.
- 36.35 Contractor shall ensure that it remains in compliance with Applicable Laws at all times and maintained registers and records with all particulars as may be specified in the Applicable Laws.

- 36.36 Payment of gratuity (if any) to Manpower will be sole responsibility of the Contractor.
- 36.37 Contractor to submit details of payments made to PF and ESIC authorities with a list of Manpower deployed at the Site with copy of deposit challans--List of Manpower with PF and ESIC numbers to maintained up to date by Contractor and if required to be shared with BYPL.

C) Contractor's Other Obligations

- 36.38 -
- 36.39 The employees deployed by the Contractor shall be employees of the Contractor.
- 36.40 At no point in time shall any employee of the Contractor claim to be the employee of the Company.
- 36.41 The Contractor is committed to recruit and provide qualified, experienced, well-trained, physically & mentally fit personnel in accordance with the Company's standard, duly verified by the local police Station as regards their antecedents and backgrounds.
- 36.42 The Contractor shall ensure that, the Contractor's manpower deployed at the Company shall be in good health, shall have proper eyesight and shall not have any medical problems which may endanger his life and the life of the other Company employees appointed at the said location. The Contractor shall ensure that, the Contractor's personnel deployed at the Company shall be entirely responsible for the stock of the commodities stored at the said location. To ensure such safety, the Contractor shall, before deploying any employee in the premises, shall have him medically examined by a registered medical practitioner at its own cost and expenses and produce a medical certificate certifying that the said employee is medically fit. It is further agreed that without such medical certificate, Company shall not permit any such Contractor's personnel to work in its premises. It is further agreed that Company may, from time to time, call upon the Contractor to have all or any of its Contractor's personnel examined.
- 36.43 The Contractor shall uphold the strictest disciplinary standards for all their personnel and any transgressions are dealt with immediately, and to the fullest extent that the law allows.
- 36.44 The Contractor shall provide uniforms to its manpower and shall provide an authority letter to the its manpower and they shall carry the same when they are on duty at the Company.
- 36.45 Whenever any Contractor's personnel go on leave, the Contractor will arrange for a suitable replacement immediately.
- 36.46 -
- 36.47 The Contractor shall fully guide, supervise and monitor the Contractor's manpower deployed in Company locations by its Supervisors.
- 36.48 Supervisors will inspect every location at least once every 15 days during day/night to check the level of control exercised by Contractor's personnel. The Supervisors will take digital photographs of Contractor's personnel in the location during their inspection. The photographs will contain date and time stamp to identify the date the photographs are taken and send the photographs to Company along with their inspection report on weekly basis.
- 36.49 The Contractor undertakes to provide required resources to maintain desired service

level. In case of any failure in services due to paucity of resources, BYPL shall be within its rights to make necessary deductions in addition to such rights as available under contract.

36.50 TIMELY DISBURSEMENT OF WAGES

The Contractor shall ensure that monthly wages/salary disbursed to its manpower timely but not later than 7th of each month. Though the company endeavours to process Contractor's bills on time as per the payment timelines mentioned in agreement (payment terms), under no circumstances delay in disbursement of wages shall be acceptable, it is the Contractor's responsibility to ensure the same, accordingly the bidders are expected to quote their rates to fulfil their obligations towards the timely disbursal of wages and all other benefits including PF/ESI/Bonus/leave pay/allowances etc.

It may please be noted that BYPL reserves the right to terminate the agreement in case of second or subsequent repeated instances of delay in disbursal of the wages.

37. THE COMPANY/BYPL'S OBLIGATIONS/RESPONSIBILITIES

- 37.1 BYPL may check the competencies of the manpower for the work for which they are deputed to ensure that requisite skill and competency levels are being met with by the Contractor.
- 37.2 BYPL shall not exercise direct control (including matters of payments, discipline and removal/termination) and supervision over the Contract Manpower and that shall be done by the Contractor. However, BYPL shall have a right to assess the abilities and skills of the Manpower deployed by the Contractor to ensure the quality of Service provided under the Contract, without actually managing or directing such Contract Manpower.
- 37.3 The contractor shall ensure to maintain the registers like muster roll, wage register, etc., and shall share the copy of the same with BYPL as and when demanded,
- 37.4 The Company/BYPL reserves the right to engage other party(ies) to perform similar or identical Services to be performed by Contractor under this Contract / Agreement for which Contractor shall not have any objections.
- 37.5 BYPL reserves right to review the resources requirement for the performance of assigned task, on periodically or preferably on monthly basis for their respective performance. The Contractor, without any objection, shall deploy resources on time accordingly. The Contractor to deploy resources within 2 days (including Central and State holidays) to Site / establishment as notified by BYPL in writing. Failure to do so shall result into delay in deploying resources for the completion of the assigned task, the reasonable compensation shall be applicable in terms of the Contract.
- 37.6 BYPL shall at all times have access to any Site where the Manpower is engaged and performing any of the Services and BYPL shall have the right to inspect performance at Site. Any deviation or gap or discrepancies arises while executing Services shall be communicated to Contractor within 3 working days. The Contractor within next two working days shall provide reasonable feedback with evidence if any to BYPL. If Contractor does

not respond to the Communication in time under this sub Article, it tantamount to breach of the Contract and shall attract reasonable compensation in terms of the Contract.

38. INDEMNITY

The Contractor shall indemnify, defend, save and hold harmless all directors, company and its employees against any and all suits, proceedings, actions, demands and third party claims for any loss, damage, cost and expense suffered by company on account of the negligence, act or omission inaction by the Contractor or its employees under this Agreement. Agencies shall also wholly indemnify and compensate company against any theft, misappropriation, fraudulent act or omission, any collusion with customer/s, intentional recording of incorrect reading/DATA, or any other offence under the applicable laws or breach of obligation under the present agreement, and would also render itself liable to appropriate legal action being initiated against it by company.

The Contractor shall also be responsible and liable to company for any loss or damage caused to company for any negligence or inaction, damage to the property of company caused by the Contractor or its employees.

39. SECRECY & CONFIDENTIALITY

- 39.1 The technical information, data and other related documents forming part of order and the information obtained during the course of investigation under this order shall be the Company's exclusive property and shall not be used for any other purpose except for the execution of the order. The technical information drawing, records and other document shall not be copied, transferred, or divulged and/or disclosed to third party in full/part, not misused in any form whatsoever except to the extent for the execution of this order.
- 39.2 These technical information, drawing and other related documents shall be returned to the Company with all approved copies and duplicates including data/drawing/plans as are prepared by the Contractor during the executions of this order, if any, immediately after they have been used for agreed purpose.
- 39.3 In the event of any breach of this provision, the Contractor shall indemnify the Company against any loss, cost or damage or claim by any party in respect of such breach.
- 39.4 The Contractor shall not use the name/logo/emblem of the Company in any manner either for credit arrangement or otherwise and it is agreed that the Company shall not in any way be responsible for the debts, liabilities or obligations of the Contractor and/or his employees.
- 39.5 The Contractor hereby covenant that the Contractor shall be responsible for theft, if any committed, by his staff and the Contractor shall indemnify Company from and against all claims, demands, actions, suits and proceedings, whatsoever that may be brought or made against the Company by or on behalf of any person, body, authority whatsoever and whomsoever and all duties, penalties, levies, taxes, losses, damages, costs, charges and

expenses and all other liabilities of whatsoever nature which the Company may be liable to pay, incur or sustain by virtue of or as a result of the performance or non- performance or observance or non- observance by the Contractor of any of the terms and conditions of this agreement. The Company shall have full power and rights at its discretion to pay or defend or compromise any suits, claims or demands brought or made, whether pending or threatened touching upon this agreement as it may consider necessary or desirable and shall be entitled to recover from the Contractor all sums of money including all legal costs, charges and expenses incurred by virtue of any such compromises which shall not be called into question by the Contractor but shall be final and binding on the Contractor.

39.6 Contractor shall submit signed NDA as per the format 4.3 attached.

40. NON-EXCLUSIVITY

The award of the work order/agreement to the Contractor shall not preclude the Company from awarding the same order for similar work at the same rates, or on any terms and conditions to other party or parties. The Company at its discretion may place the order on any other party.

41. SEVERABILITY

If any provision of this Agreement is or becomes invalid or unenforceable by the courts of any jurisdiction to which it is subject, such invalidity or unenforceability shall not prejudice the remaining provisions of this Agreement, which shall continue in full force and effect.

42. ASSIGNMENT & SUBLETTING

The Contractor shall not, without company's prior consent in writing assign or sublet or transfer any portion of services awarded to the Contractor as envisaged herein and falling under this contract. Moreover, any such consent shall not relieve the Contractor from any obligation, responsibility, or duty under this Contract.

43. ASSIGNMENT BY THE COMPANY

The rights and obligations of BYPL under the Contract shall be assignable to Affiliates, associate company, joint venture or any other company including change in Management Control and BYPL's lenders without consent of the Contractor. Upon written notice of seven Business Days (07 days) by BYPL, the Contract shall be deemed to have been assigned to the third party under this Article. This Article fulfils its meaning notwithstanding the notice is not accepted by the Contractor and BYPL shall not be obliged to the Contractor after seven days (07) of issue of any further notice.

44. NOT USED

45. NO JOINT VENTURE

The Contractor shall not constitute a joint venture, consortium or other unincorporated grouping of two or more Persons, following the execution of the Contract.

46. WAIVER OF RIGHTS

No delay or forbearance by company in exercising any right or power under this Agreement shall be construed as a waiver of such right or power, nor shall any single or partial exercise of such right or power preclude any further exercise of such right of power.

47. THE COMPANY'S RIGHT TO VARY QUANTITIES

The Company reserves the right to vary the quantity i.e. increase or decrease the Numbers/ quantities without any change in terms and conditions during the execution of the Order. BYPL may increase or reduce the area/ scale of operations after starting of execution of the contract and the size of contract may be adjusted accordingly.

48. CONTRACTOR'S EQUIPMENT

- 48.1. All Contractor's Equipment and Temporary Works provided by the Contractor or any permitted Subcontractor, shall, when brought on to the Site, be deemed to be exclusively intended for execution of the Works and not be removed without the consent, in writing, of the Company's Representative.
- 48.2. Upon completion of the Works, the Contractor/permitted Subcontractor shall remove from the Site, all its Equipment and Temporary Works and its unused materials.
- 48.3. The Company shall not at any time be liable for the loss or damage to any of the constructional plant, Temporary Works or materials.
- 48.4. The Contractor shall, upon written request by the Company's Representative, produce to the Company's Representative, all documents evidencing title to or the contractual arrangement giving the right to the Contractor to use the Contractor's Equipment. In the event of failure to comply with such request within seven (7) days, then without prejudice to any other rights, the Company shall be entitled to withhold the payments due to the Contractor under the Contract.

49. AVAILABILITY OF TOOL & PLANT (T&P)

The contractor shall provide T&P to their staff as mentioned in Scope of work. The contractor shall provide all tools in the beginning of contract and shall ensure the proper availability of tools and tackles as per that list throughout the contractual period. These tools shall be of make as specified in the Scope of work. It shall be responsibility of contractors to replenish and maintain the existing T&P on regular basis.

50. FREE ISSUE MATERIAL

- 50.1. The Company, may provide free issue materials to Contractor in those cases only where it is specifically mentioned in the tender Terms & Conditions. Transportation of free issue materials from site / store or place of availability at site to the work area shall be in scope of the contractor.
- 50.2. Contractor shall submit Reconciliation Statement of these free issue materials along with monthly bill. Reconciliation Statement will show issued quantity of free issue materials/ quantity consumed in work and quantity balance in contractor's stock.
- 50.3. The Contractor shall have to furnish an Indemnity Bond for materials which are free issued by the Purchaser. Further the contractor shall be responsible for the safe custody of materials till the materials are utilized, fabricated, erected and accounted for in all respects.

51. VENDOR CODE OF CONDUCT

Contractor confirms to have gone through the Policy of BYPL on legal and ethical code required to be followed by Vendors encapsulated in the "Vendor Code of Conduct" displayed on the official website of BYPL (www.bsesdelhi.com) also, which shall be treated as a part of the agreement.

Contractor undertakes that he shall adhere to the Vendor code of Conduct and also agrees that any violation of the Vendor Code of Conduct shall be treated as breach of the agreement.

In event of any such breach, irrespective of whether it causes any loss/damage, company (BYPL) shall have the right to recover loss/damage including liquidated damages from Contractor.

The Contractor hereby indemnifies and agrees to keep indemnified the company (BYPL) against any claim/litigation/liability/penalty including litigation cost arising out of any violation of Vendor Code of Conduct by the Contractor or its officers, agents & representatives etc.

52. DISCLOSURE OF RELATIONSHIP

The Contractor acknowledges & undertakes that the Contractor or any partner of the Contractor or director of the Contractor is not related to any of the officers of the Company or the Company's Representative, or alternatively, is a close relative of an officer of the Company or the Company's Representative and has no financial interest/stake in the Company's business. The Parties agree that breach of the above provisions shall entitle the Company to terminate the Contract under Clause 23, without payment of any compensation to the Contractor. The Contractor agrees and acknowledges and shall ensure that its employees, directors and partners do not develop any such interest during the Contract Period.

53. MSME

- 53.1. If the Contractor is covered under the definition of supplier/Contractor under the purview of Micro, Small & Medium Enterprises Development Act, 2006, it shall declare so at the

time of its registration as vendor with the Company failing which it will be presumed that it is a non-MSME unit.

- 53.2. Contractor shall provide to Company the proof of classification of its enterprise and filing memorandum with the authorities concerned under the Micro, Small & Medium Enterprises Development Act, 2006 (herein referred to as "the MSMED Act") within one week of receipt of the Contract
- 53.3. The Contractor further declares and undertakes to intimate Company of any change in its status or constitution under this section from time to time under this Contract. The Contractor must provide MSME registration number along with PAN card and GST registration number on Tax Invoice failing which the Contractor shall not claim any benefit under the MSMED Act.
- 53.4. The Contractor to furnish the undertaking to the Company in this regard.

54. COVID GUIDELINES

Looking to the prevailing Covid19 situation, Contractor will ensure that the work carried out in the field by their staff shall be as per the guidelines issued by MHA / BYPL/ Engineer-in-charge from time to time. Further Contractor shall be required to provide to their staff masks/ sanitizers/ all PPEs required for working in Covid19 situation. The Contractor shall further ensure to work as per the guidelines issued by BYPL and the instruction of the Engineer in charge.

55. CLEANLINESS & PRECAUTIONS TO BE TAKEN WHILE DOING WORK AT SITE TO PREVENT DUST POLLUTION

All debris shall be removed and disposed off at assigned areas on daily basis. Surplus excavated earth shall be disposed of in an approved manner. In short, the contractor shall be fully responsible for keeping the work site clean at all times. In case of non-compliance, company shall get the same done at Contractor's risk and costs.

While carrying out any civil work including road/ pit digging, plinth/ fence making, road restoration etc contractor shall adhere to below mentioned guidelines.

- (a) No construction material/ debris shall be stored on metalled road.
- (b) Wind breakers of appropriate height on all sides of ear marked area using CGI sheets shall be raised to ensure that no construction material dust fly outside ear marked area.
- (c) The construction material i.e. coarse sand, stone aggregates, excavated earth, cement and any other material to and from the site shall be transported under wet and covered condition to ensure their non-slippage en-route to avoid air contamination.
- (d) The contractor shall provide mask and helmet to every worker working on the construction site and involved in loading/unloading and carriage of construction material and construction debris to prevent inhalation of dust particles.
- (e) Over loading of vehicles shall be strictly prohibited
- (f) The construction material at site shall be stored under wet and covered condition.
- (g) The dumping sites for temporarily storing the excavated earth shall be properly levelled, watered and rehabilitated by plantation to avoid flying of dust.
- (h) The worker at the site shall be sensitized to adopt / observe the dust controlled

measures in true spirit.

- (i) If any C&D waste is generated at site the same will be transported to the C&D waste site only and the record for the same will be maintained by the agency.
- (j) Wet Jet in grinding and stone cutting is being permitted at site.
- (k) The necessary record for dust control is being maintained by the department on day to day basis and being monitored regularly.
- (l) Contractor shall ensure that no tree shall be harmed and no tree roots shall be destroyed/cut while performing the task under agreement.
- (m) The contractor shall comply the provisions of The Delhi Preservation of Trees Act 1994.

The Execution contractor shall be responsible for all the preventive and protective environmental steps as per guidelines. Any violations from the above guidelines have been viewed very seriously by the authorities. Contractor shall be liable for the penalties / other action by the authorities, the contractor shall indemnify BYPL from all liabilities on this account.

56. ENVIRONMENTAL, HEALTH & SAFETY

The Contractor will ensure that the Environment, Health & Safety (EHS) requirements are clearly understood and faithfully implemented at all levels at site as per instruction of Company/BYPL. Contractors must comply with the requirements, as follows:

- (i) Comply with all of the elements of the EHS Plan and any regulations applicable to the work
- (ii) Comply with the procedures provided in the interests of Environment, Health and Safety
- (iii) Ensure that all of their employees designated to work are properly trained and competent
- (iii) Ensure that all plant and equipment they bring on to site has been inspected and serviced in accordance with legal requirement and manufacturer's or supplier/Contractor s' instructions
- (iv) Make arrangements to ensure that all employees designated to work on or visit the site present themselves for site induction prior to commencement of work
- (v) Provide details of any hazardous substances to be brought onsite
- (vi) Ensure that a responsible person accompanies any of their visitors to site

All personnel deputed by Contractor under agreement shall be accountable for the following:

- (a) Use the correct tools and equipment for the job and use safety equipment and protective clothing supplied, e.g. helmets, goggles, ear protection, etc. as instructed
- (b) Keep tools in good condition
- (c) Report to the Supervisor any unsafe or unhealthy condition or any defects in plant or equipment
- (d) Develop a concern for safety for themselves and for others
- (e) Prohibit horseplay
- (f) Not to operate any item of plant unless they have been specifically trained and are authorized to do so.

57. ACCEPTANCE

Acceptance of the CONTRACT implies and includes acceptance of all terms and conditions enumerated in the CONTRACT, in the technical specification and drawings made available to the Contractor consisting of general conditions and complete scope of work. Contractor's and Company's contractual obligations are strictly limited to the terms set out in the CONTRACT.

BSES

SECTION – V : SCOPE OF WORK

BSES

SCOPE OF WORK

The contractor shall execute the all work required for the electrification of East Delhi Hub as per the tentative Bill of Quantities (BOQ) given below and the technical specification attached as Annexure V-A:

NAME OF WORK: ELECTRIFICATION OF EAST DELHI HUB,KKD			
Sno.	Description	Units	Quantity
1	Laying of HT/LT cable of following size in S/ Stn. Trench. Above 70 sq. mm up to 150 sqmm	M	200
2	Labour charges for digging of the trench of the required size including the backfilling with the excavated earth and ramming the same and disposing the surplus excavated material all complete. Payment shall be released as per actual depth excavated or as mentioned in drawing whichever is less. Digging of cable trench in Dense carpeted bituminous roads/CC Road/Asphaltic Road for 11KV H.T. 3X150/300/400 sq.mm Single Circuit of size 400X1055 mm as per Drg.# 6 and Type A-2.	M	1500.0
3	Laying of under- ground HT. cable in trench ,docketing with bricks & sand as per BSES specifications, refilling the trench and ramming the surface & removal of malba if any, including supply of IInd class bricks and sand (Sand cushion min 75mm below and 75mm above the cable. Also a warning tape above 224 mm of the docket be laid.) and including watch and ward till charging of cable of size 3X150/300/400 sq.mm.11KV.Single Circuit, as per Drg.#6, Type A-2.	M	1500.0
4	Crossing of roads by trench-less technology by laying of HDPE pipe excluding supply of pipe. Laying by HDD Machine Moiling. Drilling and laying.160mm dia.	M	5500.0
5	Supply of HDPE pipes as per IS 4984,PN 4 class PE 63 - 160mm dia.	M	5500.0
6	Laying of HT/LT cables through GI Pipe /RCC Hume pipe. above 150 sq.mm	M	5500.0
7	Laying of HT/LT cable of following size in S/ Stn. Trench. Above 150 sq.mm.	M	1000.0

8	Charges for carrying out Route survey and identification of underground utilities of various civic agencies before/during execution of scheme involving cable laying work. Route length will be considered for payment. Route will be specifically verified by DGM.	M	8000.0
9	High Voltage test of 11KV 3x300/3X400sq.mm cable - Testing Equipment to be provided by the contractor.	EA	30.0
10	Transportation of Electrical equipment's or any kind of materials from store to site or from site to site including loading and unloading at both ends by using T & P such as Tripod/cranes -> By Full body truck load (9T capacity). Note: - Above item will be selected ensuring optimum utilization of the approved rates.	TRP	47.0
11	Transportation of Electrical equipment's or any any kind of materials from store to site or from site to site including loading and unloading at both ends by manually -> By Half Body Truck. Note: - Above tem will be selected ensuring optimum utilization of the approved rates.	TRP	47.0
12	Digging of joints pits as required, docketing with bricks and sand of the joint & refilling with loose earth and ramming the surface including removal malba. Brick and sand shall be supplied by the contractor	EA	32.0
13	Digging of Test pit of the required size at site for identification of the cable along with refilling with loose earth and ramming the surface including removal of Malba. The volume of this shall be deducted from Item Labour charges for digging of this schedule (Only for those test pit which are lying on the cable digging route). For Dense Carpet/CC Portion/Asphaltic Road Portion.	CUM	55.0
14	Disconnection or Connection of 11KV XLPE Cable of following sizes: 3cX 300/3cx400 sq.mm.	EA	53.0
15	Disconnection or Connection of 11KV XLPE Cable of following sizes: 3cX 150 sq.mm.	EA	20.0
16	Making of I/D jt. box	Nos.	60.0
17	Making of s. jt. box	Nos.	32.0
18	Transportation of empty cable drum from site to designated store anywhere in Delhi. For minimum 11 no's Wooden Drum (In case under execution No. of empty drum are less than 11 nos. the same can be transported against one transportation charges)	TRP	10.0

19	Cleaning and clearing of malba after completion of work at site or removal of malba to carry out the work at site (This item is not applicable for removal of malba in digging and cable laying and Pole erection work)	CUM	1000.0
20	Transportation of material by hand-cart	TRP	90.0
21	Barricading Item for Electrical & Road restoration work Providing and Erecting Continuous Steel Barricading (MS sheet) of size 1.80 mtrs x 1.20 mtrs at site as per drawing / direction of Engineer-in-Charge which includes cost of material, plant, consumable, transport & labour for shifting, placing, painting, arrangement for traffic diversion such as traffic signals during construction at site for day and night, glow lamp, reflective signs, marking, flags, caution tape etc and regular maintenance complete. The barricading provided shall be retained in position at site continuously i/c shifting of barricading from one location to another location as many times as required during the execution of the entire work till its completion. The barricading shall not be removed without prior approval of Engineer-in-Charge. “(Note: - Onetime payment shall be made for providing barricading from start of work till completion of work i/c shifting. The barricading provided shall remain to be the property of the contractor on completion of the work).	M	8000.0
22	RMU installation 4- Function.	EA	10.0
23	Testing and commissioning comprising of Hi-pot test, primary injection, IR & mV Drop test for 4-Function RMU.	EA	10.0
24	Casting of civil foundation for each 4-way RMU. It includes cement, sand, ballast (rodi)and labour.	EA	10.0
25	Extra civil work for step-making (required for smooth operation/maintenance of RMU's)if the RMU is to be installed more than 300mm height from Ground Level.	EA	10.0
26	Supply & Erection of MS Frame for 4-Way RMUs.	EA	10.0
27	Transportation of RMU's and other materials from Main Store to Distt.Store or from Distt.Store to site, i/c.loading & unloading at both ends safely (a) One transport will be paid per site for New RMU along with other materials. (b) In case of transshipment of RMU from main store to district store and then from district store to site, two transport will be allowed.	TRP	20.0

28	Fabrication work using MS steel (for any type & as per drawing, specification provided by BSES) including all consumables i.e. welding rods, supplying and providing 2 coats of red oxide primer and one coat of aluminium paint, nuts, bolts and washers. All type frames, structure, clamps etc. Steel shall be provided by Contactor.	KG	3250.0
29	Supply and laying of 50 x 6 mm G I strip to connect all earth electrode in parallel with double connection to the transformer / any switch gear as per site requirement	M	1200.0
30	Earthing with 100 mmX6 meter., GI pipe of B class with Masonry earth pit enclosure on top covered having locking watering arrangement with funnel I/C provision of salt charcoal as per IS 3043. (Resistance should be less than 1 ohm) Salt, charcoal, masonry material and top enclosure cover and all the earthing material shall be provided by contractor.	EA	80.0
31	Painting of nomenclature of size(s) as reqd. on FP/Service Pillar / LT Panel / HT Panel and LT ACBs etc. including supply of paint. Rates are per alphabet	EA	4000.0
32	Transportation of Electrical equipment's or any any kind of materials from store to site or from site to site including loading and unloading at both ends by manually -> By Half Body Truck. Note:- Above tem will be selected ensuring optimum utilization of the approved rates	TRP	20.0
33	Installation, testing and commissioning of 11/0.433 KV distribution Transformer of following sizes on existing plinth including grouting of frames required on HT & LT side for cables as per BSES Design & practice. 2MVA Dry Type Transformer any type.	EA	20
34	Dragging of Old/New Distribution Transformers of 400 KVA to 2MVA rating of oil/dry type as per standard practice from more than 10 metre to 30 mtrs.	EA	10
35	Dragging of Old/New Distribution Transformres of 400KVA to 2MVA rating of oil/dry type as per standard practice from more than 30 metre to 60 mtrs.	EA	10
36	Dragging of Old/New Distribution Transformres of 400KVA to 2 MVA rating of oil/dry type as per standard practice for more than 60 mtrs (rates are per metre)	M	500

37	Laying and connecting of 11KV cable of size 3x150 sq. mm. from HT switch gear to the transformer and LT single core cable of size 630 sq. mm. from TR to LT board including fixing the same by means of proper wooden cleats etc. as required (The work includes crimping of sockets earthing & taping etc. as req). For 990 KVA Transformer	EA	20
38	Providing and Fabrications of wooden cleats for supporting LT S/C cable from transformer to LT board with suitable size of holes as required. (Material will be supplied by the contractor). Cleats with 7-11 holes	EA	10
39	Providing and Fabrications of wooden cleats for supporting HT cable from Transformer to H.T. Switchgear with suitable size of holes as required. (Material will be supplied by the contractor). Cleats with single hole for HT cable	EA	10
40	Supply & Installation of fire buckets filled with sand, including fabrication of frame/stand of suitable size, canopy, grouting on surface or wall, painting of frame including necessary hardware and consumables. 4 bucket stand	SET	10
41	Fixing of fire extinguishers/ bucket by means of proper hooks clamps etc. as required including grouting and painting of hooks/clamps.	EA	10
42	Making of masonry plinth for placing the transformer with 90cm height above the ground level and 30cm below ground complete with bricks, cement, badarpur in the ratio of 1:6 and duly plastered on all sides Plinth to be provided with 75mm PCC layer on top.	CUM	150
43	Providing, supplying and laying minimum 150 mm thick gravel filling after cleaning and levelling of site. Size of gravel should be between 20mm including dressing, compacting etc. All stone used shall be granite stone free from dirt or organic material.	CUM	300
44	Supplying and filling in plinth with Jamuna sand under floors including, watering, ramming consolidating and dressing complete.	CUM	300
45	Supply and fixing of wire mesh fencing 2.5 metre height with gate frame of 3 metre x 2.5 metre with complete material including painting e.g. angle, chain link, wire mesh and civil material etc. complete as per specification & drawing of BSES. Angle iron size 50x50x6 mm & MS strip 50 x 3 mm, Wire mesh 1"x3" of 8 SWG wire to be used for wire-mesh with providing support at 1.25m distance.	SQM	400

46	Sheet for covering s/stn.	SQM	300
47	Concreting with 1:3:6 mix complete in all respect.	CUM	250

BSES

SECTION – VII: PRICE BID

BSES

SECTION – VI : PRICE BID

NAME OF WORK: ELECTRIFICATION OF EAST DELHI HUB,KKD					
Sno.	Description	Units	Quantity	Price (Exclusive GST)	Total
a	b	c	d	e	f=e*c
1	Laying of HT/LT cable of following size in S/ Stn. Trench. Above 70 sq. mm up to 150 sqmm	M	200		
2	Labour charges for digging of the trench of the required size including the backfilling with the excavated earth and ramming the same and disposing the surplus excavated material all complete. Payment shall be released as per actual depth excavated or as mentioned in drawing whichever is less.Digging of cable trench in Dense carpeted bituminous roads/CC Road/Asphaltic Road for 11KV H.T. 3X150/300/400 sq.mm Single Circuit of size 400X1055 mm as per Drg.# 6 and Type A-2.	M	1500.0		
3	Laying of under- ground HT. cable in trench ,docketing with bricks & sand as per BSES specifications, refilling the trench and ramming the surface & removal of malba if any, including supply of IInd class bricks and sand (Sand cushion min 75mm below and 75mm above the cable. Also a warning tape above 224 mm of the docket be laid.) and including watch and ward till charging of cable of size 3X150/300/400 sq.mm.11KV.Single Circuit, as per Drg.#6, Type A-2.	M	1500.0		
4	Crossing of roads by trench-less technology by laying of HDPE pipe excluding supply of pipe. Laying by HDD Machine Moiling. Drilling and laying.160mm dia.	M	5500.0		

5	Supply of HDPE pipes as per IS 4984, PN 4 class PE 63 - 160mm dia.	M	5500.0		
6	Laying of HT/LT cables through GI Pipe /RCC Hume pipe. above 150 sq.mm	M	5500.0		
7	Laying of HT/LT cable of following size in S/ Stn. Trench. Above 150 sq.mm.	M	1000.0		
8	Charges for carrying out Route survey and identification of underground utilities of various civic agencies before/during execution of scheme involving cable laying work. Route length will be considered for payment. Route will be specifically verified by DGM.	M	8000.0		
9	High Voltage test of 11KV 3x300/3X400sq.mm cable - Testing Equipment to be provided by the contractor.	EA	30.0		
10	Transportation of Electrical equipment's or any kind of materials from store to site or from site to site including loading and unloading at both ends by using T & P such as Tripod/cranes -> By Full body truck load (9T capacity). Note: - Above item will be selected ensuring optimum utilization of the approved rates.	TRP	47.0		
11	Transportation of Electrical equipment's or any any kind of materials from store to site or from site to site including loading and unloading at both ends by manually -> By Half Body Truck. Note: - Above tem will be selected ensuring optimum utilization of the approved rates.	TRP	47.0		
12	Digging of joints pits as required, docketing with bricks and sand of the joint & refilling with loose earth and ramming the surface	EA	32.0		

	including removal malba. Brick and sand shall be supplied by the contractor				
13	Digging of Test pit of the required size at site for identification of the cable along with refilling with loose earth and ramming the surface including removal of Malba. The volume of this shall be deducted from Item Labour charges for digging of this schedule (Only for those test pit which are lying on the cable digging route). For Dense Carpet/CC Portion/Asphaltic Road Portion.	CUM	55.0		
14	Disconnection or Connection of 11KV XLPE Cable of following sizes: 3cX 300/3cx400 sq.mm.	EA	53.0		
15	Disconnection or Connection of 11KV XLPE Cable of following sizes: 3cX 150 sq.mm.	EA	20.0		
16	Making of I/D jt. box	Nos.	60.0		
17	Making of s. jt. box	Nos.	32.0		
18	Transportation of empty cable drum from site to designated store anywhere in Delhi. For minimum 11 no's Wooden Drum (In case under execution No. of empty drum are less than 11 nos. the same can be transported against one transportation charges)	TRP	10.0		
19	Cleaning and clearing of malba after completion of work at site or removal of malba to carry out the work at site (This item is not applicable for removal of malba in digging and cable laying and Pole erection work)	CUM	1000.0		
20	Transportation of material by hand-cart	TRP	90.0		
21	Barricading Item for Electrical & Road restoration work Providing and Erecting Continuous Steel Barricading (MS sheet) of size 1.80 mtrs x 1.20 mtrs at site as per drawing /	M	8000.0		

	<p>direction of Engineer-in-Charge which includes cost of material, plant, consumable, transport & labour for shifting, placing, painting, arrangement for traffic diversion such as traffic signals during construction at site for day and night, glow lamp, reflective signs, marking, flags, caution tape etc and regular maintenance complete. The barricading provided shall be retained in position at site continuously i/c shifting of barricading from one location to another location as many times as required during the execution of the entire work till its completion. The barricading shall not be removed without prior approval of Engineer-in-Charge. “(Note: - Onetime payment shall be made for providing barricading from start of work till completion of work i/c shifting. The barricading provided shall remain to be the property of the contractor on completion of the work).</p>				
22	RMU installation 4- Function.	EA	10.0		
23	Testing and commissioning comprising of Hi-pot test, primary injection, IR & mV Drop test for 4-Function RMU.	EA	10.0		
24	Casting of civil foundation for each 4-way RMU. It includes cement, sand, ballast (rodi)and labour.	EA	10.0		
25	Extra civil work for step-making (required for smooth operation/maintenance of RMU's)if the RMU is to be installed more than 300mm height from Ground Level.	EA	10.0		
26	Supply & Erection of MS Frame for 4-Way RMUs.	EA	10.0		

27	Transportation of RMU's and other materials from Main Store to Distt.Store or from Distt.Store to site, i/c.loading & unloading at both ends safely (a) One transport will be paid per site for New RMU along with other materials. (b) In case of transshipment of RMU from main store to district store and then from district store to site, two transport will be allowed.	TRP	20.0		
28	Fabrication work using MS steel (for any type & as per drawing, specification provided by BSES) including all consumables i.e. welding rods, supplying and providing 2 coats of red oxide primer and one coat of aluminium paint, nuts, bolts and washers. All type frames, structure, clamps etc. Steel shall be provided by Contactor.	KG	3250.0		
29	Supply and laying of 50 x 6 mm G I strip to connect all earth electrode in parallel with double connection to the transformer / any switch gear as per site requirement	M	1200.0		
30	Earthing with 100 mmX6 meter., GI pipe of B class with Masonry earth pit enclosure on top covered having locking watering arrangement with funnel I/C provision of salt charcoal as per IS 3043. (Resistance should be less than 1 ohm) Salt, charcoal, masonry material and top enclosure cover and all the earthing material shall be provided by contractor.	EA	80.0		
31	Painting of nomenclature of size(s) as reqd. on FP/Service Pillar / LT Panel / HT Panel and LT ACBs etc. including supply of paint. Rates are per alphabet	EA	4000.0		

32	Transportation of Electrical equipment's or any any kind of materials from store to site or from site to site including loading and unloading at both ends by manually -> By Half Body Truck. Note:- Above tem will be selected ensuring optimum utilization of the approved rates	TRP	20.0		
33	Installation, testing and commissioning of 11/0.433 KV distribution Transformer of following sizes on existing plinth including grouting of frames required on HT & LT side for cables as per BSES Design & practice. 2MVA Dry Type Transformer any type.	EA	20		
34	Dragging of Old/New Distribution Transformers of 400 KVA to 2MVA rating of oil/dry type as per standard practice from more than 10 metre to 30 mtrs.	EA	10		
35	Dragging of Old/New Distribution Transformres of 400KVA to 2MVA rating of oil/dry type as per standard practice from more than 30 metre to 60 mtrs.	EA	10		
36	Dragging of Old/New Distribution Transformres of 400KVA to 2 MVA rating of oil/dry type as per standard practice for more than 60 mtrs (rates are per metre)	M	500		
37	Laying and connecting of 11KV cable of size 3x150 sq. mm. from HT switch gear to the transformer and LT single core cable of size 630 sq. mm. from TR to LT board including fixing the same by means of proper wooden cleats etc. as required (The work includes crimping of sockets earthing & taping etc. as req). For 990 KVA Transformer	EA	20		
38	Providing and Fabrications of wooden cleats for supporting LT S/C cable from transformer to LT board with suitable size of holes as required. (Material will be supplied by the contractor). Cleats with 7-11 holes	EA	10		

39	Providing and Fabrications of wooden cleats for supporting HT cable from Transformer to H.T. Switchgear with suitable size of holes as required. (Material will be supplied by the contractor). Cleats with single hole for HT cable	EA	10		
40	Supply & Installation of fire buckets filled with sand, including fabrication of frame/stand of suitable size, canopy, grouting on surface or wall, painting of frame including necessary hardware and consumables. 4 bucket stand	SET	10		
41	Fixing of fire extinguishers/ bucket by means of proper hooks clamps etc. as required including grouting and painting of hooks/clamps.	EA	10		
42	Making of masonry plinth for placing the transformer with 90cm height above the ground level and 30cm below ground complete with bricks, cement, badarpur in the ratio of 1:6 and duly plastered on all sides Plinth to be provided with 75mm PCC layer on top.	CUM	150		
43	Providing, supplying and laying minimum 150 mm thick gravel filling after cleaning and levelling of site. Size of gravel should be between 20mm including dressing, compacting etc. All stone used shall be granite stone free from dirt or organic material.	CUM	300		
44	Supplying and filling in plinth with Jamuna sand under floors including, watering, ramming consolidating and dressing complete.	CUM	300		
45	Supply and fixing of wire mesh fencing 2.5 metre height with gate frame of 3 metre x 2.5 metre with complete material including painting e.g. angle, chain link, wire mesh and civil material etc. complete as per specification & drawing of BSES. Angle iron size 50x50x6 mm & MS strip 50 x 3	SQM	400		

	mm, Wire mesh 1"x3" of 8 SWG wire to be used for wire-mesh with providing support at 1.25m distance.				
46	Sheet for covering s/stn.	SQM	300		
47	Concreting with 1:3:6 mix complete in all respect.	CUM	250		
			A	Total	
			B	GST@ 18%	
			C	Grand Total(A+B)	

NOTE:

- 1) Prices quoted above shall remain firm for entire duration of the contract from the date of award of contract.
- 2) The bidder shall quote the prices strictly in the above format / item description / content. The bid shall be liable for rejection, if contractor fail to do so. If at any stage, the content is found to be changed from the given price format, the content as per the given price format will prevail and binding on the contractor
- 3) The bidder needs to quote for all the line items as mentioned above; failing which the bids are liable for rejection.

ANNEXURE –I : BID FORM

To,

**Head of Department,
Contracts & Material Department,
BSES YAMUNA Power Ltd,
IIIrd Floor, A Block,
Shakti Kiran Building, Karkardooma,
Delhi 110032.**

Dear Sir,

- 1 We understand that BYPL is desirous of awarding the contract for..... (Name of the Work) work in its licensed distribution network area in Delhi.
- 2 Having examined the Tender Documents for the above named works, we the undersigned, offer to deliver the goods/services in full conformity with the Terms and Conditions, technical specifications & Scope of Work as may be determined in accordance with the terms and conditions of the contract. The quoted amounts for this work are in accordance with the Price Schedules attached herewith and are made part of this bid.
- 3 If our Bid is accepted, we undertake to deliver the entire goods/services as per delivery/ completion schedule mentioned in Section III from the date of award of order/letter of intent.
- 4 If our Bid is accepted, we will furnish a Contract Cum Performance Bank Guarantee (CPBG) for due performance of the Contract in accordance with the Terms and Conditions of the NIT.
- 5 We agree to abide by this Bid for a period of 180 days from the due date of bid submission and it shall remain binding upon us and may be accepted at any time before the expiration of that period.
- 6 We declare that we are aware of the provision of all Laws associated with the supply of equipment's/materials or Services and the prices have been quoted accordingly.
- 7 Unless and until Letter of Intent is issued, this Bid, together with your written acceptance thereof, shall constitute a binding contract between us.
- 8 We understand that BYPL is not bound to accept the lowest, or any bid BYPL may receive.
- 9 There is provision for Resolution of Disputes under this Contract, in accordance with the Laws and Jurisdiction of Contract.
- 10 We do hereby agree and shall abide the terms of tender documents/agreement, in full

Dated this..... day of..... 2023

Signature..... In the capacity of

.....duly authorized to sign for and on behalf of

(IN BLOCK CAPITALS)

ANNEXURE – II : BIDDER'S DETAILS

S.No.	Item	Description
1	Company Name	
2	BYPL Vendor Code (If Registered)	
3	Area of Specialization	
4	Company Founded Year	
5	Type of Company	
6	Constitution(Company Registration number)	
7	Name of Director / Mobile Number	
8	Name of other main person / Mobile Number	
9	Vendor Address	
10	Vendor Contact no	
11	Vendor Email ID	-
12	No. of Manpower on payroll (Executive/Skilled/Semi-Skilled/Un-skilled)	-
13	No. of Contractual Manpower (Executive/Skilled/Semi-Skilled/Un-skilled)	-
14	Other Office / Factory Address	
15	ISO certification	
16	PAN	
17	PF/ESI	
18	Shop Establishment Certificate (If Applicable)	
19	Electrical License Detail (If Applicable)	
20	GST	
21	GST Registration Date	
22	SSI	
23	MSME Registration Number (If Applicable)	
24	Turn Over FY 2018-19 (Rs. Cr.)	
25	Turn Over FY 2019-20 (Rs. Cr.)	

S.No.	Item	Description
26	Turn Over FY 2020-21 (Rs. Cr.)	
27	Turn Over FY 2021-22 (Rs. Cr.)	
28	Profit after Tax FY 2018-19 (Rs. Cr.)	
29	Profit after Tax FY 2019-20 (Rs. Cr.)	
30	Profit after Tax FY 2020-21 (Rs. Cr.)	
31	Profit after Tax FY 2021-22 (Rs. Cr.)	
32	Networth (Rs Cr.)	
33	Bank Guarantee Limit (in Cr.)	
34	Over Draft/Cash Credit Limit (in Cr.)	
35	Present Order Booking (Rs Cr.)	
36	Order executed with Reliance ADA (Rs Cr.)	
37	Name & Detail of relative working in BYPL	
38	Main Customer	
39	Details of orders executed / Under Execution	Please submit the details in Attachment - A

ATTACHMENT – A

Reference List of Order Executed / under Execution by the Vendor (M/s)

A) Major Orders Executed

<u>SN</u>	<u>Name of Project</u>	<u>Client name & address</u>	<u>Client contact Detail</u> (<u>Person name,</u> <u>e-mail ID,</u> <u>Mobile & landline number</u>)	<u>Vend or's Scope of Work</u>	<u>Date Of Award</u>	<u>Value of Work (Rs in Lakhs)</u>	<u>Completion date as per Order</u>	<u>Actual Completion Date</u>	<u>LD/ Penalty imposed, if any (Rs in Lakhs)</u>	<u>Litigation / Arbitration (Y/N) (If Yes, furnish details)</u>	<u>Remarks</u>
1.											
2.											
3.											
4.											
5.											

B) Orders Under Execution

<u>SN</u>	<u>Name of Project</u>	<u>Client name & address</u>	<u>Client contact Detail</u> (<u>Person name,</u> <u>e-mail ID,</u> <u>Mobile & landline number</u>)	<u>Vend or's Scope of Work</u>	<u>Date Of Award</u>	<u>Value of Work (Rs in Lakhs)</u>	<u>Completion date as per Order</u>	<u>Actual Completion Date</u>	<u>LD/ Penalty imposed, if any (Rs in Lakhs)</u>	<u>Litigation / Arbitration (Y/N) (If Yes, furnish details)</u>	<u>Remarks</u>
1.											
2.											
3.											
4.											
5.											

ANNEXURE – III

ACCEPTANCE FORM FOR PARTICIPATION IN REVERSE AUCTION EVENT

(To be signed and stamped by the bidder prior to participation in the auction event)

BYPL intends to use the reverse auction through SAP-SRM tool as an integral part of the entire tendering process. All the bidders who are found as techno commercially qualified based on the tender requirements shall be eligible to participate in the reverse auction event.

The following terms and conditions are deemed as accepted by the bidder on participation in the bid event:

1. BYPL shall provide the user id and password to the authorized representative of the bidder. (Authorization letter in lieu of the same be submitted along with the signed and stamped acceptance form)
2. BYPL will make every effort to make the bid process transparent. However, the award decision by BYPL would be final and binding on the supplier/Contractor.
3. The bidder agrees to non-disclosure of trade information regarding the purchase, identity of BYPL, bid process, bid technology, bid documentation and bid details.
4. The bidder is advised to understand the auto bid process to safeguard themselves against any possibility of non-participation in the auction event.
5. In case of bidding through internet medium, bidders are further advised to ensure availability of the entire infrastructure as required at their end to participate in the auction event. Inability to bid due to telephone line glitch, internet response issues, software or hardware hangs; power failure or any other reason shall not be the responsibility of BYPL.
6. In case of intranet medium, BYPL shall provide the infrastructure to bidders, further, BYPL has sole discretion to extend or restart the auction event in case of any glitches in infrastructure observed which has restricted the bidders to submit the bids to ensure fair & transparent competitive bidding. In case of an auction event is restarted, the best bid as already available in the system shall become the start price for the new auction.
7. In case the bidder fails to participate in the auction event due any reason whatsoever, it shall be presumed that the bidder has no further discounts to offer and the initial bid as submitted by the bidder as a part of the tender shall be considered as the bidder's final no regret offer. Any offline price bids received from a bidder in lieu of non-participation in the auction event shall be out rightly rejected by BYPL.
8. The bidder shall be prepared with competitive price quotes on the day of the bidding event.
9. The prices as quoted by the bidder during the auction event shall be inclusive of all the applicable taxes, duties and levies and shall be FOR at BYPL site.
10. The prices submitted by a bidder during the auction event shall be binding on the bidder. No further communication will be there.

11. No requests for time extension of the auction event shall be considered by BYPL.
12. The original price bids of the bidders shall be reduced on pro-data basis against each line item based on the final all-inclusive prices offered during conclusion of the auction event for arriving at contract amount.

For.....

Signature:

Name:

Designation:

BSES

ANNEXURE – IV:

ENVIRONMENTAL, OCCUPATIONAL HEALTH & SAFETY CONDITIONS OF CONTRACT

1.0 General Requirements

- 1.1 The contractor shall ensure that safety of all the workers, materials, Installation and equipment's belonging to him or to others and working at the site is ensured through effective and practicable safety management systems.
- 1.2 The contractor shall be responsible for compliance to provisions of all safety requirements under various notices, acts, rules and relevant applicable legislations.
- 1.3 The contractors shall comply with all health & safety requirements as deemed necessary by BYPL from time to time.
- 1.4 Works shall be carried out by the contractor after taking necessary "Permit to work". Also the work shall not be carried out without use of Protective equipment's like shoes, safety belts, helmets etc. adhering to safety compliance.
- 1.5 All the equipment's being used shall be timely calibrated and a copy of the same shall be submitted to Safety Department within 4 weeks of the acceptance of contract and thereafter on every renewal.

2.0 EHS Policy

The contractor as per requirement of CEA Measures Relating to Safety and Electric Supply Regulations, 2010 shall follow the Environment, Health & Safety policy of BYPL. The contractor shall implement quality, health & safety management systems in accordance to BYPL EHS policy and ensure that intentions of such policy are met.

3.0 Health & Safety Plan

- 3.1 Within 4 weeks of the notification of acceptance of the tender, the contractor shall submit a detailed and comprehensive Contract specific health & safety plan incorporating HIRA (Hazard Identification & Risk Analysis) to BYPL. This plan shall necessarily include detailed policies, procedures, method statement for each activity to be performed and regulations which, when implemented, will ensure compliance of the contract provisions stated herewith.
- 3.2 The contractor shall submit health & safety plan for such activities required to be carried out under the awarded contract as deemed necessary by BYPL.
- 3.3 Health & safety plans, procedures, method statements, etc. developed & submitted by

contractors shall be reviewed and approved by designated authorities of BYPL (Head Safety). First cut of the plan shall be submitted to Safety Department within 2 weeks of agreement of contract. After suggested rectification, the final plan shall be submitted to Head Safety not later than 4 weeks of the agreement of contract. A copy of the same shall be given to the engineer in charge also. The document shall carry the signatures of the authorized signatory (the person who has signed the agreement document of contract).

- 3.4 The health & safety plans, procedures, method statements, etc. shall not be changed without prior review and approval by designated authorities of BYPL.

4.0 OHS Organization & Responsibility

- 4.1 The contractor supervisor will play the role of safety supervisor. The safety supervisor shall hold a diploma degree from a recognized institute or university as per CEA Regulations, 2010. Also simultaneously contractor has to ensure their competency in safety or EHS with 40 hours training from reputed agency (like RLI/Allied Boston/ National Safety Council) or trainer, which should be verified earlier by BYPL safety department accordingly. The copy of training certificate shall be submitted to Safety Department within 4 weeks of agreement of contract. Time extension may be given in extraordinary situation subjected to submission of any convincing document carrying valid proof of near future plan of the training.

- 4.2 The training certificate should not be more than one-year-old.

- 4.3 Apart from above, as an owner of the company the contractor & their other key persons are also responsible for safety compliance and related issues.

5.0 First Day at Work –Induction Training and Issuance of ID-Card

- 5.1 The contractor shall ensure that all his workers have undergone the safety induction and have been issued with a valid ID card prior to start work at BYPL site. The proof of the same shall be submitted to Safety Department within 4 weeks of agreement of contract.

- 5.2 All contractor workers shall undergo above as per the BYPL site specific procedure issued from time to time.

- 5.3 The contractor shall ensure that no worker is in any O&M activities until the valid ID card is issued and the same is available by each worker at site including that of sub-contractor(s).

5.4 In case any worker lost the ID card issued to him, the contractor shall ensure that such incidences are promptly reported to BYPL and duplicate or new ID card is issued immediately after completing formalities as deemed necessary by BYPL.

6.0 Provision of Safe Working Conditions

6.1 Proper barricading shall be created during height work, cable laying work, working on pole, etc. Dimensions of barricading while cable laying work- Height- 2 mtr, Length- 1.5 mtr. There shall not be any gap in between two barricades. LED Bacon light shall be placed at 1st and every 4th barricade. However, while working on pole during supply maintenance work there should be a barricading cone and caution tape . In narrow lanes, where proper barricading as per rules is not possible, use barricading as per the approval of respective safety circle head in writing and copy forwarded to safety and uploading in QMS.

6.2 PPE' Requirement

6.2.1 The contractor shall ensure all the required PPEs given in clause 6.2 and shall allow their workers to start work at site only after proper verification of adequacy of safety gears/PPE required for the specific job at site by the Safety personnel/Site Engineer of BYPL.

Contractor has to ensure the quantity and quality of PPEs during procurement and continuous usage of following PPE's by his staff.

S.NO.	NAME OF THE PPEs	LINEMAN / FITTER/SKILLED	HELPER/UNSKILLED	SUPERVISOR
1	SAFETY HELMET	✓	✓	✓
2	FULL BODY HARNESS (POSITIONING BELT)	✓	X	X
3	ELECTRICAL HAND GLOVES	✓	✓	X
4	SAFETY SHOES	✓	✓	✓
5	SAFETY GOGGLES	✓	✓	✓
6	REFLECTIVE JACKET	✓	✓	✓

6.2.2 Contractor has to ensure for proper procurement and distribution of required PPE's among their workers with receiving in attached format (Appendix-3) which will be verified by the safety department during inspection. The entire issuance format duly signed by individual worker and to be verified/ certified by Department Head and the same need to be submitted to Safety Department along with mentioned certificates within 4 weeks of agreement of

contract. The sample of the PPE's being procured by the contractor shall be submitted and approved from the Safety Department beforehand.

6.2.3 The contractor has to provide 3 arc protection face shields in each zone (2 for complaint team and 1 for maintenance team) as per specifications mentioned in clause 6.2.5.6.

6.2.4 If any of the contractor staff found without PPEs, the said PPE's will be issued to them from BYPL store with immediate effect. And the 20% extra amount with procurement cost will be recovered from their next monthly bill cycle.

Note: PPEs shall strictly be as per the brand mentioned in clause 6.2.5

6.2.5 Technical Specification of the PPEs

6.2.5.1. Safety Shoes – With Composite / Fiber toes (CE approved / IS 15298) – Mandatory for all personnel working at BYPL O&M. The safety shoes shall meet the following features:

1. Electric Shock Resistant Sole
2. Impact Resistant
3. Scrap/Heat Resistant
4. Slip Resistant
5. Oil and Acid Resistant
6. Rubber PU Sole
7. Anti-puncture

Lead MAKE: BATA/HONEYWELL/KARAM

6.2.5.2 Safety Helmets: (IS 2925 - 1984 or DGMS) with chin strap – Mandatory for all personnel working at BYPL O&M. The specification of safety helmet shall be as given below:

V-GARD HDPE Yellow With 4 Point Fas Trac Ratchet Suspension

Shell Material	UV stabilized HDPE, Non vented
Suspension	<ul style="list-style-type: none"> • With 4 Point Fas Trac Ratchet Suspension sewn headband • Textile straps made from polyester Suspension • point fixing: good positioning, ...stability, better air circulation due to ...limited contact areas with the head

	<ul style="list-style-type: none"> • Easy clean sweatband
Size	52-62 cm
Accessory slot	Standard 30 mm with removable HDPE dead plugs suitable to leak proof fitting
Approvals	ANSI/ IEC Z89.1 Class E (electrical)
Additional	Low temperature -10°C (acc. to GB2811), High temperature +50°C
Colours	Yellow
weight	360 g

Lead MAKE: 3M / KARAM / UFS

6.2.5.3 Full Body positioning Harness: (CE approved / IS 3521 / EN 361 / EN 355) – Shall be used while work is in progress at height more than 1.8 meter or where from a person may fall and get injured. The specification of the Full body harness shall be as given below:

Anchorage	Adjustable two chest attachment D-rings and A dorsal attachment D-ring
Adaptability	Adjustable shoulder and thigh straps
Convenience	Shoulder and thigh straps differentiated by a dual color scheme.
Ergonomics	Ideally. Positioned sit strap for extended comfort.
Size	Standard
weight	1200GMS
ENERGY ABSORBING FORKED LANYARDS :	
Spec.	44mm wide polyamide webbing.
Length	1.5 Meter

There should not be any metallic part in the full body harness.

Lead MAKE: KARAM /LIFEGEAR/UFS/HONEYWELL

6.2.5.4 Flex Chem Full View Safety Goggles – Shall be used to protect workers eyes from foreign materials and flying particles. Mandatory for all personnel working at BYPL O&M. Safety goggles shall meet the following feature:

1. Acetate lens for special applications requiring superior chemical resistance.
2. Industrial version of tough and popular first responder goggles.
3. Soft Flex low profile frosted frame for increased comfort.
4. Comfortable headband with length adjustment.
5. Indirect venting for comfortable, long lasting wear can be worn with safety helmets and over prescription spectacles.
6. Sight Gard + premium anti-fog coating (EN 166 “N”) with good anti- scratch properties.

Technical Specification:

Weight	95g.
Lens thickness	1.0mm
Overall width	173mm
Overall length	90mm
Bridge	47.6mm
Lens base	5.5 curve
Lens size	86.1mm verticle, 174mm diagonal
Headband	Adjustable length at max.440mm(long enough to fit together with helmets)
Material & colors	
Lens	Acetate clear, coating, Sightgard + anti-fog according to EN 166 “N” & anti scratch.
Body	PVC smoke
Headband holder	Nylon
Headband	Adjustable grey elastic fixed on frame side parts
Marking / Approvals	
Standard number	EN 166
Frame marking	MSA EN 166 34-FT CE
Lens marking	2C-1.2 MSA 1 FT N CE
Filter class	2C (Ultra violet radiation with enhanced color recognition)
Scale number	1.2: luminous trasmittance-89%
Optical class	1 (best class, for permanent wear)
Mechanical resistance	F (low energy impact 45m/s) T (at extreme temperature - 5 to +55 ⁰ C)

Resistance to	N(distorted vision due to lens fogging)
UV filter	99.9%
Ordering information	10145578-FlexiChem Sightgard + clear , 6x

Lead MAKE: MSA / UVEX/ UFS/3M/KARAM

6.2.5.5 Electrical Insulating Hand Gloves – Shall be used to prevent electric shock based upon the hazards/risks involved in a particular activity. Safety goggles shall meet the following features:

- Breakthrough manufacturing process for exception dry grip.
- Soft and flexible for enhanced tactility, high dexterity and wearer comfort.
- Ergonomic design featuring tapered fingers to reduce hand fatigue.
- Relaxed wrist for easy on/off.

	For LT work	For HT work
Length	360mm	360mm
Class	2	0
Thickness	3.6mm	1mm
Proof test voltage	20000	5000
Maximum use voltage	11000	1000
Tensile strength	>16mpa[Mega Pascal]	
Puncture resistance	>18N/mm [Newton per mili meter]	
Elongation at break	>600% [Stretching length]	
Tension set	<15%	

- It should be resistant to oil, acid, ultra violet rays and very low temperature.
- Each pair of glove should be marked with class, category, month & year of manufacturing, CE logo, batch no. and certified laboratory no.
- EN certified to electrical and thermal hazards,
- EN certified to thermal & electrical hazards to confirm EN 60-903,
- EN certified to mechanical hazard to EN-388

Lead MAKE: Honeywell / ANSELL/CATU

6.2.5.6 Arc Protection Face Shield

- a) ATPV value is 10 cal/cm²
- b) It shall have a slotted hard hat and chin guard
- c) Visible light transmission (VLT) shall be 70%
- d) It should have anti fog lens
- e) It should have a provision for replacement of lens and brackets.
- f) It should cover the complete face and the complete neck region.
- g) It must not hinder the work. Must be comfortable for the height jobs as well as in the ground.
- h) Carry bag for the kit.

Lead MAKE: Oberon/Honeywell

6.2.5.7 Certificates required for all PPEs:

- 1. Manufacturer Certificate
- 2. Test Certificate
- 3. Authorization of Dealership/Distribution ship

The copy of all the certificates shall be submitted to safety department within 4 weeks of agreement of contract.

7.0 Integrated Management System & Audits

- 7.1 The Contractor shall work in the framework of Integrated Management System (IMS) and shall maintain documentation as prescribed in the IMS Manual of BYPL. IMS Manual can be obtained directly from site engineer/Division Head/Respective Head.
- 7.2 All contractors during their currency of contract shall strive to continuously improve and demonstrate strict compliance to ISO 9001, 14001 & 45001 standards of BYPL.
- 7.3 To verify compliance and to continually improve the management system, all contractors shall be subjected to both internal & external audits.

8.0 Medical Examination

- 8.1 -

8.2 Records of medical examination as described above shall be maintained at the contractor premises and a copy of the same shall be submitted to Safety Department within 4 weeks of agreement of contract.

8.3 No person about whom the Contractor knows or has reason to believe that he is a deaf or he has a defective vision or he has a tendency to giddiness shall be required or allowed to work in any O&M operation or other construction work which is likely to involve a risk of any accident either to the worker himself or to any other person.

9.0 Working at Height

9.1 The Contractor shall ensure that all works carried out at a height of 2 Meter or more shall only be started after obtaining a permit to work at height, which shall be issued as per the procedure of BYPL by authorized personnel.

9.2 The contractor shall ensure that all control measures mentioned and agreed through above work permit or as deemed necessary by BYPL are enforced and complied all the time during activities carried out at height.

9.3 Full body harness and ladder along with the required PPEs shall be used during height work.

9.4 Barricading cone and tape shall be used along with creation of proper safety zone.

10.0 Reporting of Near Miss/ Incidents / Dangerous Occurrences

10.1 In case of any incident/ accident occurs during the O&M activities undertaken by the Contractor thereby causing a dangerous occurrence or near miss or any minor or major or fatal injury to his employees due to any reason, whatsoever, it shall be sole responsibility of the Contractor to promptly inform the same to Department Head in prescribed form and also to all authorities envisaged under the applicable laws.

11.0 Suspension of Work

11.1 BYPL shall have the right at its sole discretion to suspend the work till compliance of safety norms, if in its opinion the work is being carried out in such a way that it may cause accidents and endanger the safety of the persons and / or property, and / or equipments.

- 11.2 In such cases, the contractor shall be informed in writing about the nature of hazards and possible injury /accident and he shall comply to remove all shortcomings promptly. Decision of BYPL shall be conclusive and binding on the Contractor in such aspects.
- 11.3 The contractor shall not be entitled to damages / compensation for suspending of work due to safety reasons and the period of such stoppage of work will not be taken as an extension of time for completion of the facilities as per the work order and will not be the ground for wavier of levy of liquidated damages.
- 11.4 The contractor shall follow and comply with all safety Rules of BYPL, relevant provisions of applicable laws pertaining to the safety of workmen, employees plant and equipment as may be prescribed from time to time without any demur, protest or contest or reservation. In case of any nonconformity between statutory requirement and safety rules of the BYPL referred above, the latter shall be binding on the contractor unless the statutory provisions are more stringent.

12.0 OHS Appreciation Policy

- 12.1 If the contractor observes all the safety rules and codes, statutory laws and rules during the period of the contract awarded by the BYPL and no accident occurs then BYPL may consider the performance of the contractor and safety score card will be prepared. The best contractor will be appreciated by suitable "SAFETY AWARD" as per scheme as may be announced separately from time to time.

13.0 Safety Motivational Scheme for Contractor Employee

- 13.1 All contractors must reward their employee monthly for best worker in term of complying safety norms. They should honour with a gift of Rs. 500/- (five Hundred) with commendation certificate to motivate others towards safety compliance. The record with photograph should kept with them & also to be submitted to BYPL safety department. Contractor may ask to BYPL safety people for their presence during awarding time.
- 13.2 All contractors have to observe safety day/ week on 4th March to 10th march every year with proper planning and record to create safety awareness inside their organization. A detailed report of observing the same to be forwarded to safety department every year.

14.0 Guidelines for Penalty Policy Implementation

- 14.1 Total penalty shall be calculated by multiplying the number of safety violations and the penalty amount specified for such violations in **Appendix - 1. (Example – If at first offence persons are found working without safety helmet at 3 locations, the penalty**

would be 3X2000 = Rs.6000/-)

- 14.2 The amount of penalty can be increased or decreased based upon the seriousness of safety violations. The decision of recommending authority shall be final one.
- 14.3 Recommending authority shall send his factual observations to Department Head and Safety Head who in turn shall either reject or approve it. If approved, he shall send it to Finance & Accounts for execution. Finance Accounts shall execute the penalty and confirm the same & shall send it back to Department Head and Safety Head.
- 14.4 Recommending Authority means the Department Head, HODs, Site Safety officer / Supervisor, representatives from OHS and other personnel authorized jointly by O&M.
- 14.5 Penalties will be imposed for delay in submission of EHS related requirements/documents mentioned in the contract. Once the contract is accepted, the requirements as mentioned in **Appendix- 2 to be submitted within 4 weeks.**
- 14.5 Safety Head may impose penalty for serious violations directly.
- 14.6 All penalties shall be imposed directly on the concerned contractors. No penalty shall be imposed on individuals.

15.0 Guidelines for Safety Appreciation Policy Implementation

- 15.1 Recommending Authority shall write comments of his Appreciation in case he observes that there is no any safety violations.
- 15.2 Recommending Authority shall send his Safety Appreciation to Safety Head who in turn shall either approve or reject it and shall send it to Site Safety Officer for keeping in records.
- 15.3 Management will appreciate the Safe Contractors for their best performance towards safety norms based upon number of safety appreciation notes.
- 15.4 Every year best Safe Contractor shall be suitably awarded. The contractor shall be selected based upon the maximum numbers of approved safety appreciation notes.
- 15.5 Any contractor who has received any penalty for a particular year shall not be entitled for Safe Contractor's Award irrespective of number of safety appreciation notes he has

received.

- 15.6 Site Safety Officer will maintain the contractor wise record of penalty & safety appreciation notes and declare the results latest by 28th February of every year for the performance of previous year.
- 15.7 BYPL Management shall present a Trophy with commendation certificate of safety excellence every year on the occasion of 4th to 10th March (National Safety Day) to the contractor, who qualified the safety standard criteria.

BSES

Appendix – 1

Penalty Policy on Safety Violation

	Type of Offense	Penalty Detail	Execution Channel
A	<p>Not Wearing Safety Helmets Safety shoes/ Safety Goggles / Electrical insulating hand gloves/ reflective jacket/Not using electrically safe tools and equipments. (Poor quality or damaged item means noncompliance)</p>	<p># First Offence - Warning Note & Rs.2000/-</p> <p># Second Offence - Warning Note & Fine of Rs.5000/-</p> <p># Third Offence- Note of recommendation of the concerned workmen/ supervisors for removal from deployment with BYPL& Fine of Rs.15000/-</p>	<p>Recommendation by OHS-Representative/Department Head</p> <p>Approval by Safety Head</p> <p>Deduction by Finance & Account</p>
B	<p>Not wearing Full Body Harness/fall arresters while working at a height more than 1.8 meter or where from a person may fall. Not using Safety Net to arrest falling objects and personnel.</p> <p>Not using Arc Protection Face Shield</p> <p>Not using barricading cone and tape.</p> <p>(Poor quality or damaged item means noncompliance)</p>	<p># First Offence -Warning Note & Fine of Rs.5000/-</p> <p># Second Offence - Warning Note for dismissal and a Fine of Rs.10000/-</p> <p># Third Offense - -Action for the concerned Workmen/ supervisor for removal from deployment with BYPL and a fine of Rs.25000/-</p>	<p>Recommendation by OHS-Representative/Department Head</p> <p>Approval by Safety Head</p> <p>Deduction by Finance & Account</p>
C	<p>Any other unsafe work practices or condition which is considered having potential for fatality or injury to personnel.</p>	<p># First Offence - Warning Note & Fine of Rs.10000/-</p> <p># Second Offence - Action for the concerned workmen/ supervisors for removal from deployment with BYPL and fine of Rs.20000/-.</p>	<p>Recommendation by OHS-Representative/Department Head</p> <p>Approval by Safety Head</p> <p>Deduction by Finance & Account</p>

Notes:

Refer clause No. 14 for penalty policy implementation guidelines

If there are 03 violations by an individual employee, his removal from deployment with BYPL # If there are 10 violations in one quarter, will be recommended for termination of contract order.

Appendix – 2

Penalty Policy on non- submission of EHS related requirements

Following EHS related requirements to be submitted within 4 weeks of agreement of contract

Requirement	Penalty Detail	Execution Channel
1. Contract specific health & safety plan and HIRA (Hazard Identification & Risk Analysis)		
2. Safety supervisor training records on EHS (40 hrs training)		
3. Submission of sample of PPE's in EHS department for approval (if procured by the contractor)	Delay of 15 days- Warning Note & Consolidated Fine of Rs.5000/- on non-submission of proof of any of these mentioned 8 types of documents	
4. Bills/challan of PPE's along with test certificates (if procured by the contractor)	On every subsequent delay of 15 days- Warning Note & Consolidated Fine of Rs. 10,000/- on non-submission of proof of any of these mentioned 8 types of documents	Recommendation by OHS-Representative Approval by Safety Head Deduction by Finance & Account
5. PPE's receipt by worker (as per Appendix-3)		
6. Medical examination record of workers		
7. ID card of workers		
8. Calibration Certificates of equipment's		

Appendix – 3

Format for PPE's Receipt by workers

Name of Site -----

Division-----

Name of Contractor -----

S. N O.	NAME	DESI.	Safety Helmet	Electrical Insulating Hand gloves	Full Body Harness	Safety Shoes	Safety Goggle	Reflective Jacket	SIGNATURE

Signature of Contractor / Date.....

FORMAT – 4.1

EMD BANK GUARANTEE

(To be issued in a Non Judicial Stamp Paper of Rs.100/-purchased in the name of the bank)
Whereas [name of the Bidder] (herein after called the “Bidder”) has submitted its bid dated [date of submission of bid] for the supply/services of [name and/or description of the goods/sevices] (here after called the “Bid”). KNOW ALL PEOPLE by these presents that WE [name of bank] at [Branch Name and address], having our registered office at [address of the registered office of the bank] (herein after called the “Bank”), are bound unto BSES YAMUNA Power Ltd., with its Corporate Office at SHAKTI KIRAN BUILDING, KARKARDOOMA, Delhi 110032, (herein after called —the “Purchaser”) in the sum of (Rupees only) for which payment well and truly to be made to the said Purchaser, the Bank binds itself, its successors, and assigns by these presents. Sealed with the Common Seal of the said Bank this _____ day of _____ 2023. The Conditions of this obligation are:

1. If the Bidder withdraws its Bid during the period of bid validity specified by the Bidder on the Bid Form;
- or
2. If the Bidder, having been notified of the acceptance of its Bid by the Purchaser during the period of bid validity:
 - (a) Fails or refuses to execute the contract form, if required: or
 - (b) Fails or refuses to furnish the performance security, In accordance with the instructions to Bidders/Terms and Conditions.

We undertake to pay to the Purchaser up to the above amount upon receipt of its first written demand, without the Purchaser having to substantiate its demand, provided that is its demand the purchaser will note that amount claimed by it is due to it, owing to the occurrence of one or both of the two condition(s), specifying the occurred condition or condition(s). This guarantee will remain in force up to and including 180 days after the due date of submission bid, and any demand in respect thereof should reach the Bank not later than the above date.

(Stamp & signature of the bank)

Signature of the witness(s)

FORMAT – 4.2

PROFORMA OF CONTRACT CUM PERFORMANCE BANK GUARANTEE

(TO BE ISSUED ON RS 100/- STAMP PAPER)

This Guarantee made at _____ this [____] day of [____] 2023

1. WHEREAS **M/s BSES Yamuna Power Limited**, a Company incorporated under the provisions of Companies Act, 1956 having its Registered Office at **Shakti Kiran Building, Karkardooma, Delhi 110032**, India hereinafter referred to as the “Company”, (which expression shall unless repugnant to the context or meaning thereof include its successors, administrators, executors and assigns).
2. AND WHEREAS the Company has entered into a contract for _____ (Please specify the nature of contract here) vide Contract No. _____ dated _____ (hereinafter referred to as the “Contract”) with M/s. _____, (hereinafter referred to as “Contractor”, which expression shall unless repugnant to the context or meaning thereof be deemed to mean and include each of their respective successors and assigns) for providing services on the terms and conditions as more particularly detailed therein.
3. AND WHEREAS as per clause ____ of General Conditions of Contract, the Contractor is obliged to provide to the Company an unconditional bank guarantee for an amount equivalent to ten percent (10%) of the total Contract Value for the timely completion and faithful and successful execution of the Contract from [_____] pl. specify the name of Bank) having its head/registered office at [_____] through its branch in _____ (pl. specify the name of Branch through which B.G is issued) hereinafter referred to as “the Bank”, (which expression shall unless it be repugnant to the context or meaning thereof be deemed to include its successors and permitted assigns).
4. NOW THEREFORE, in consideration inter alia of the Company granting the Contractor the Contract, the Bank hereby unconditionally and irrevocably guarantees and undertakes, on a written demand, to immediately pay to the Company any amount so demanded (by way of one or more claims) not exceeding in the aggregate [Rs.].....(in words) without any demur, reservation, contest or protest and/or without reference to the Contractor and without the Company needing to provide or show to the Bank ,grounds or reasons or give any justification for such demand for the sum/s demanded.
5. The decision of the Company to invoke this Guarantee and as to whether the Contractor has not performed its obligations under the Contract shall be binding on the Bank. The Bank acknowledges that any such demand by the Company of the amounts payable by the Bank to the Company shall be final, binding and conclusive evidence in respect of the amounts payable by the Supplier to the Owner. Any such demand made by the Owner on the Bank shall be conclusive and binding, notwithstanding any difference between the Owner and the Contractor or any dispute raised, invoked, threatened or pending before any court, tribunal, arbitrator or any other authority.
6. The Bank also agrees that the Company at its option shall be entitled to enforce this Guarantee against the Bank as a principal debtor without proceeding against the

Contractor notwithstanding any other security or other guarantee that the Company may have in relation to the Contractor's liabilities.

7. The Bank hereby waives the necessity for the Company first demanding the aforesaid amounts or any part thereof from the Contractor before making payment to the Company and further also waives any right the Bank may have of first requiring the Company to use its legal remedies against the Contractor, before presenting any written demand to the Bank for payment under this Guarantee.
8. The Bank's obligations under this Guarantee shall not be reduced by reason of any partial performance of the Contract. The Bank's obligations shall not be reduced by any failure by the Company to timely pay or perform any of its obligations under the Contract.
9. The Bank further unconditionally and unequivocally agrees with the Company that the Company shall be at liberty, without the Bank's consent and without affecting in any manner its rights and the Bank's obligation under this Guarantee, from time to time, to:
 - (i) Vary and/or modify any of the terms and conditions of the Contract;
 - (ii) Forebear or enforce any of the rights exercisable by the Company against the Contractor under the terms and conditions of the Contract; or
 - (iii) Extend and/or postpone the time for performance of the obligations of the Contractor under the Contract;

and the Bank shall not be relieved from its liability by reason of any such act or omission on the part of the Company or any indulgence shown by the Company to the Contractor or any other reason whatsoever which under the law relating to sureties would, but for this provision, have the effect of relieving the Bank of its obligations under this Guarantee.

10. This Guarantee shall be a continuing bank guarantee and shall not be discharged by any change in the constitution or composition of the Contractor, and this Guarantee shall not be affected or discharged by the liquidation, winding-up, bankruptcy, reorganization, dissolution or insolvency of the Contractor or any of them or any other circumstances whatsoever.
11. This Guarantee shall be in addition to and not in substitution or in derogation of any other security held by the Company to secure the performance of the obligations of the Contractor under the Contract.
12. NOTWITHSTANDING anything herein above contained, the liability of the BANK under this Guarantee shall be restricted to _____ (insert an amount equal to ten percent (10%) of the Contract Value) and this Guarantee shall be valid and enforceable and expire on _____ (pl. specify date) or unless a suit or action to enforce a claim under this Guarantee is filed against the Bank on or before the date of expiry.
13. On termination of this Guarantee, all rights under the said Guarantee shall be forfeited and the Bank shall be relieved and discharged from all liabilities hereunder.
14. The Bank undertakes not to revoke this Guarantee during its validity except with the prior written consent of the Company and agrees that any change in the constitution of the Bank or the Contractor shall not discharge our liability hereunder.

15. Company may assign this Guarantee to any Person or body whether natural, incorporated or otherwise under intimation to the Bank. The Bank shall be discharged of its obligations hereunder by performance in accordance with the terms hereof to such assignee without verifying the validity / legality / enforceability of the assignment.
16. This Guarantee shall be governed by the laws of India. Any suit, action, or other proceeding arising out of, connected with, or related to this Guarantee or the subject matter hereof shall be subject to the exclusive jurisdiction of the courts of Delhi, India.
Dated this day of2023 at

(Signature)
.....

(Name)
.....

(Designation with Bank Stamp)

Attorney as per

Power of Attorney No.....

Date.....

Beneficiary's bank detail with IFSC Code:

1. Name of the Bank : State Bank of India
2. Branch Name & Full Address: Industrial Finance Branch, 14-15 Floor,
Jawahar Vaypar Bhawan, 1, Tolstoy Marg, New Delhi
110001
3. Bank Account No: 10277791808
4. IFSC Code: SBIN0009601

Vendor has to fill this form & submit along with the PERFORMANCE BANK GUARANTEE

1. Bank Email ID-----Bank Phone No-----
2. Where to Dispatched the BG -Local Address of bank -----
3. Where to Dispatched the BG Head Office Address -----

FORMAT – 4.3

NON-DISCLOSURE AGREEMENT

THIS NON-DISCLOSURE AGREEMENT ("Agreement") is made and entered into at Delhi on the ____ day of _____, 2023

By And Between

M/s BSES Yamuna Power Limited, a company registered under the Companies Act, 1956 and having its registered office at **Shaktikiran Building, Karkardooma, Delhi 110032** (hereinafter referred to as the "Disclosing Party" which expression shall unless repugnant to the meaning and context mean and include its successors and permitted assigns) of the FIRST PART

And

_____, a company incorporated under the Companies Act, 1956 and having its registered office at _____, (hereinafter referred to as the "Receiving Party" which expression shall unless repugnant to the meaning and context mean and include its successors and permitted assigns) of the OTHER PART

Disclosing Party and Receiving Party are hereinafter individually referred to as the "Party" and collectively as the "Parties".

WHEREAS the Disclosing Party is in discussions with the Receiving Party for Security Management Services ("Project") and the Disclosing Party may in conjunction with the aforesaid disclose to the Receiving Party information relating to their businesses which is confidential and sensitive in nature and the Receiving Party is willing to undertake to restrict the use and further disclosure of the information in accordance with the terms and conditions set out herein:

1. The "Receiving Party" acknowledges and confirms the confidential and sensitive nature of all information, documents and material relating to Persons and entities which may be accused of or related to the theft of electricity which is a penal offense under the provisions of the electricity act 2003As well as the various data and tools which may be available by way of documents as well as other modes of proof("Project") (i) that may be disclosed or made available to the Receiving Party by the Disclosing Party or its employees/ representatives/ advisors/ consultants; (ii)Receiving Party may gain or gather from any source; (iii) Receiving Party may process or arrive at during the course of the Project; (iv) Receiving Party may have come across during its discussions with any person in the course of the Project; and (v) all negotiations and discussions between the Parties relating to the Project (all the information referred to above is hereinafter referred to as the "Confidential Information").
2. Confidential Information is understood to include but is not limited to information

made available in written, machine recognizable, graphic or sample form including, without limitation, drawings, photographs, models, design or performance specifications, its analysis, compilations, studies, notes and all other information and data disclosed orally or visually which has been developed / is exclusive to the Disclosing Party and includes information provided in various meetings.

Provided, however, that Confidential Information shall not include information which (a) is, or becomes, publicly known, otherwise than through a wrongful act of the Receiving Party or its representatives; (b) is in the possession of the Receiving Party prior to receipt from the Disclosing Party or its representatives without an obligation of confidentiality; (c) is independently developed by the Receiving Party, provided that it was not derived from the Confidential Information; (d) is furnished to others by the Disclosing Party without restrictions, similar to those herein on the rights of such others to use or disclose; or (e) is approved in writing by the Disclosing Party for disclosure.

3. The Receiving Party shall not disclose the Confidential Information to any other person save and except with the express consent in writing given by the Disclosing Party. The Receiving Party, however, may disclose such part of the Confidential Information where (i) such disclosure is in response to a valid order of a court or any other governmental body having jurisdiction over this Agreement or (ii) such disclosure is otherwise required by law, provided that Receiving Party has given prior written notice to the Disclosing Party forthwith it came to learn about such disclosure requirement or the demand for such for disclosure and made all reasonable efforts to protect the Confidential Information in connection with such disclosure.
4. The Receiving Party shall with reference to the Confidential Information take all actions as may be necessary to (i) maintain the confidentiality thereof; (ii) limit its use of such Confidential Information solely for the purpose of the Project; (iii) avoid disclosure even to any of its employees that are not associated with the Project; (iv) avoid any dissemination or publication by any of its employees/ representatives associated with the Project; (v) avoid writing about sensitive information which is disclosed verbally and is sensitive to the operations; and (vi) safeguard the Confidential Information from being accessed by any unauthorized person. Such actions shall include but not be limited to obtaining appropriate non-disclosure undertakings from its employees directly or indirectly engaged in the Project.
5. The Receiving Party hereby agrees to indemnify and hold harmless the Disclosing Party and its directors and employees from and against any damage, loss, cost or liability (including all expenses and costs of enforcing rights under the Agreement) arising out of or resulting from (i) any use or disclosure by the Receiving Party of Confidential Information in violation of the Agreement; (ii) any leakage of the Confidential Information at the end of the Receiving Party or its employees/ representatives; and (iii) breach or violation of any of the other covenants herein.

6. The Receiving Party will, promptly upon the request of the Disclosing Party, deliver to the Disclosing Party, the documents comprising the Confidential Information or any part thereof and will destroy any copies, notes, or extracts thereof, without retaining any copy thereof, except that any portion of the Confidential Information that consists of analysis and any written Confidential Information not so requested and returned, shall be retained and kept subject to the terms of this Agreement, or upon the Disclosing Party's request destroyed (such destruction to be confirmed in writing).
7. The term of this Agreement is 3 years from the date of execution of this Agreement. However, the obligation to maintain confidentiality of the Disclosing Party's information shall survive the termination of this Agreement. Any violation of this agreement may lead to termination of all the relations with the Receiving party and black listing/ debaring of the Agency for future engagements.
8. This Agreement shall be governed by the laws of India. Any dispute, difference or claim related to or arising under, out of or in connection with this Agreement shall be resolved subject to the jurisdiction of Delhi Courts.

For the Disclosing Party

Authorized Signatory

Name:

Designation:

For the Receiving party

Authorized Signatory

Name:

Designation:

FORMAT – 4.4

NO DEVIATION DECLARATION

NO DEVIATION –A(Technical)

NIT NO & DATE:

DUE DATE OF TENDER:

We hereby accept all terms and conditions of the technical scope of work as mandated in the tender documents subject to the following deviations as mentioned against the applicable technical qualifying requirement:

S.NO.	SL.NO OF TECHNICAL SPECIFICATION/SCOPE OF WORK	DEVIATIONS, IF ANY

SIGNATURE & SEAL OF BIDDER

NAME OF BIDDER

Note-The above template is indicative only, May vary depending on the nature of procurement/value.

NO DEVIATION –B(Commercial)

NIT NO & DATE:

DUE DATE OF TENDER:

We hereby accept all terms and conditions of the commercial requirement as mandated in tender document subject to the following deviations as mentioned against the applicable commercial qualifying requirement:

S.NO.	S. NO OF COMMERCIAL REQUIREMENTS	DEVIATIONS, IF ANY

SIGNATURE & SEAL OF BIDDER

NAME OF BIDDER

Note:-It is important to explicitly include all such terms and conditions which are considered absolutely necessary to be accepted by bidder without any deviation. Tender document shall have a stipulation that deviation to such criteria shall make the bid liable for rejection.

FORMAT – 4.5

BIDDER'S COMMUNICATION DETAILS

Bidder should furnish the below details for future communication: -

<u>GENERAL INFORMATION</u>	
NAME OF Company	
POSTAL ADDRESS	

FOR TECHNICAL QUERY:		
CONTACT PERSON & DESIGNATION	NAME	DESIGNATION
E-MAIL	MOBILE NO	TELEPHONE NO

FOR COMMERCIAL QUERY:		
CONTACT PERSON & DESIGNATION	NAME	DESIGNATION
E-MAIL	MOBILE NO	TELEPHONE NO

Note: No communication shall be entertained from any other email id, except as mentioned above. Bidder needs to inform the company if any changes in the email id on their letter head duly signed by the authorized signatory.

BSES RAJDHANI

BSES YAMUNA

**TECHNICAL SPECIFICATION
FOR
LAYING OF 66/33/11/1.1KV GRADE
PVC / XLPE CABLES**

GN101-03-SP-06-00

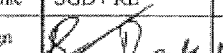
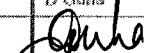
Prepared by:		Checked by :		Approved by:		Rev	Date
Name	DS	Name	SGD / RL	Name	D Guha	A	
Sign		Sign		Sign			

Index

General Specification	3
1.0.0 Codes & standards	3
2.0.0 Design Guidelines & Parameters for Cable laying	3
3.0.0 General Guidelines for Laying Cables	8
4.0.0 Testing	17
5.0.0 Progress Reporting.....	18
6.0.0 Drawing, Data & manuals	19
7.0.0 Deviations	19
Annexure # 1 – DEVIATION REPORT FORMAT.....	20
Annexure # 2 – DC HIGH VOLTAGE TEST	21
Annexure # 3 – CABLE TRENCH TYPE.....	22
Annexure # 4 – STANDARD ROAD PROFILE	23
Annexure # 5 – ROAD RESTORATION SECTIONAL DRAWINGS	25
<u>Annexure # 6 – DRAWINGS (CABLE TRENCH AND RCC CABLE COVER)</u>	<u>258</u>

General Specification

1.0.0 Codes & standards

Materials, equipment and methods used in the Laying of 11/33/66KV Cable shall conform to the latest edition of following –

Indian Standards

	Indian Electricity Rules, 1956
	Indian Electricity Act, 1910
	Indian Electricity Supply Act, 1948
	Electricity Laws Act, 1991
	National Electrical Code (Indian standards Institution)
IS 1255	Code of practice for installation and maintenance of Power Cable upto and including 33KV rating.
IS 1554	PVC Insulated Electrical Cables upto 11KV
IS 2274	Code of Practice for electrical wiring installation – system voltage exceeding 650V
IS 7098 Part II	Crosslinked Polyethylene Insulated PVC sheathed cables for working voltages from 3.3KV upto and including 33KV
IS 7098 Part III	Crosslinked Polyethylene Insulated PVC sheathed cables for working voltages from 66KV upto and including 220KV
IS 5820	Specification of precast concrete Cable cover.

2.0.0 Design Guidelines & Parameters for Cable laying

2.1.0	Selection of the route	<p>The cable route selection shall be done by the concerned supervising engineer by first conducting route survey and selecting a route along with contractor keeping followings in mind-</p> <ul style="list-style-type: none"> - The side of road, which presents the least obstacles and the fewest roadways crossings. - The future consumers and existing cables in the route may influence the cable route. - Railway, road crossings, MCD and other government agencies may also influence in selection of cable route. - Plans for future building projects should be considered. - The route shall be as far as possible away from parallel running gas, water pipes and telephone/telecommunication cables.
2.2.0	Clearances	<p>The desired minimum clearances are as follows –</p> <ul style="list-style-type: none"> - Power cable to power cable – A minimum clearance equal to diameter shall be maintained. Trench drawings shall be

		<p>referred to for guidance.</p> <ul style="list-style-type: none"> - Power Cable to control cables – 0.2 M - Power cable to communication cable – 0.3M - Power cable to gas/water main – 0.3 M
2.3.0	Depth of Cable Laying	<p>The desired minimum depth of laying from ground surface to the top of cable shall be</p> <ul style="list-style-type: none"> 650 / 1100V grade XLPE Cables – 75 cm 6.35 / 11KV grade XLPE Cables – 90 cm Low voltage and Control cable - 75 cm 19 / 33KV grade XLPE Cables - 1.05 M 38 / 66KV grade XLPE Cables - 1.20 M Cables at Road crossing - 1.0 M (min.) Cables at railways level crossings (measured from bottom of sleepers to the top of Pipe) - 1.0 M (min.) <p>Whenever there is any obstacle at the laying depth, the cable should be lowered/ raised to cross the obstacle. However variation in the depth is to be approved by BSES. The Contractor shall provide the same in deviation report.</p>
2.4.0	Width of Cable trenches	<p>The width and depth of Cable Trenches shall depend upon number of circuits and Voltage Grade. Annexure # 3 and drawings of this specification shall be followed.</p>
2.5.0	Bending Radius of Cables	<p>While pulling of the Cable from the drum or during laying following minimum bending radius shall be maintained so that the cable, in particular the insulation does not get damaged –</p> <p>A) Single Core Cables (PVC & XLPE)</p> <ul style="list-style-type: none"> Upto 11KV grade – 15 X D Above 11KV grade - 20 X D <p>B) Multi Core Cables (PVC & XLPE)</p> <ul style="list-style-type: none"> Upto 1.1KV grade - 12 X D Above 1.1KV grade – 15 X D <p>Where 'D' is overall diameter of the cable.</p>
2.6.0	Maximum permissible Tensile Strength for Cables	<p>For cables pulled with Stocking</p> <ul style="list-style-type: none"> PVC and XLPE SWA Armoured cables $P = 30 \times D$ PVC and XLPE AWA Armoured cables $P = 20 \times D$ <p>Where P= pulling force in Kgrm, D= Diameter of Cable in mm</p> <p>For Cables pulled by Cable eyes</p>

		<p>Aluminium conductor – 30 N/mm² = 3 Kg/sq. mm</p> <p>Copper conductors - 50N/mm² = 5 Kg/sq. mm</p> <p>Permissible force is calculated by multiplying the above values by cross sectional area (CSA) of conductor of each core and then number of cores.</p> <p>Pulling by tractor trolley is not allowed.</p>
2.7.0	Methods of Laying	<p>a) Cables shall be laid in direct in ground, in trenches excavated therein and shall be protected with covers as given in the drawing. Cables shall also be drawn into pipes of ducts or laid in the formed trenches or troughs or on racks or supported in trays or cleats as required by the site exigencies. Where the cables are laid in the formed trenches, the installation shall include removal and replacement of the trench covers and the provision of temporary protective covers on the trenches where they cross the access ways.</p> <p>b) HDPE (100 / 200 mm or suitable size) or RCC ducts shall be used where cable cross roads and railways tracks. Spare ducts for future extensions should be provided. Spare duct should be sealed off. Buried ducts or ducting blocks shall project into footpath or upto the edge of road, where there is no footpath, to permit smooth entry of cable without undue bending. The diameter of the cable conduit or pipe or duct should be at least 1.5 times the outer diameter of the cable. Angular alignment of the duct across road crossings shall be predetermined to maintain safe bending radius when direction of cable trench changes before or after the road.</p> <p>c) The contractor shall lay cable by horizontal direct drilling (HDD) in main roads and highway with heavy traffic, passage to public property where excavation is not possible. Contractor shall take approval for laying of cable by means of HDD wherever required from the supervising engineer. The cable laid by HDD shall be minimized so that it doesn't exceed by 12% of total route length. As per site conditions and site requirement engineer in-charge can allow laying of complete route length with HDD. The</p>

		<p>engineer in-charge shall put a note / justification for the same and get it approved from competent authority.</p> <p>d) Unless approved by BSES, the contractor shall lay the cables, direct in ground, in single layer. The cables shall be laid with the pre-determined and approved cable route.</p> <p>e) Spacing shall be maintained uniformly between the cables all along the length including the bends, as approved by BSES. To maintain the spacing, suitable non-metallic formers shall be placed uniformly with spacing not exceeding 5 meters. Every bend shall have at least one spacer.</p> <p>f) 75 mm of the sand bed shall be placed at the bottom of cable trench.</p> <p>g) After the cables have been laid the trench shall be filled with the sand and shall be well rammed to a level not less than 75 mm above the top of the cables all throughout the route.</p> <p>h) To protect the cables against external mechanical damage, which may be caused by other agencies, the cable shall be protected by suitable cover.(for drawing of RCC cable cover refer annexure VI). The type of the covers shall be as under</p> <ul style="list-style-type: none"> - 1.1KV Cables – Single layer of brick thickness not less than 75 mm (3 inch) Brick shall be laid across the cable i.e. length of brick shall be perpendicular to route of cable. - 11KV Cables–sand stone of thickness not less than 75mm (3 inch). - 33KV Cables shall be protected by reinforced concrete cover of width 300 mm as per attached drawing with thickness not less than 50mm. - 66KV Cables shall be protected by reinforced concrete cover as per attached drawing with thickness not less than 50mm. <p>The RCC cable cover shall be embossed as “BSES EHV CABLE”.</p> <p>i) Back fill to be filled up to 75mm and the warning tape shall be installed continuously. The tape shall be yellow in colour with Black / Red lettering of minimum 20mm height.</p>
--	--	---

		<p>The approved warning message shall be written in English, Hindi and local language. The minimum thickness and width of the tape should be 300 microns and 150 mm respectively.</p> <p>j) The trench shall be filled-up by soft soil (300mm) and Excavated soil as indicated in drawings.</p>
2.8.0	Cable over Bridges	<p>On Bridges the cables are generally supported on wooden cleats and clamped on steel supports at regular intervals. The cables laid on bridges shall be provided with Sun shield. Approval from appropriate authorities (PWD/railways) as applicable shall be taken by contractor.</p>
2.9.0	Laying of Single Core Cables	<p>a) The single core cables (66KV) shall be laid in trefoil formation. Single core cables can be laid individually in 200mm HDPE pipe in case of HDD only.</p> <p>b) For single core cables laid in trefoil formation, plastic cable ties shall be used at interval of 1.0 (one) meter through out the cable length to maintain the trefoil arrangement.</p> <p>c) To balance the inductance, the phase sequence as shown here below shall be maintained. (For double circuit)</p> <div style="text-align: center;"> <p style="text-align: center;"> A₁ A₂ C₁ B₁ B₂ C₂ </p> </div> <p>d) To prevent magnetic losses (eddy current and hysteresis losses), the base plate of the panels or the terminal box of the equipments, shall have aluminum plate. In case the entry into the building is through GI pipe; a "slit" in the GI pipe shall be necessary. Alternatively GI pipes may altogether be avoided and non-metallic HDPE pipes shall be used. <u>Concrete pipes having steel reinforcement (RCC pipe) are not to be used.</u></p>
2.10.0	Earthing and cross bonding	<p>a) Single point bonded earthing shall be employed to prevent flow of induced circulating current in the armour and screen</p>

	of Single Core Cables	<p>and consequential de-rating of cables for feeder less than 1.0 KM.</p> <p>b) For feeder length more than 1.0 KM, the contractor shall get the cross bonding design from BSES and ensure that cable is laid in coordination with cross bonding joint supplier.</p> <p>c) Cable laying contractor shall coordinate and ensure required pits are provided at the points where cross bonding is required as per design calculation.</p> <p>d) In case of any damage to 66KV Cable due to laying of cable without cross bonding the contractor shall bear the cost of damage to cable and any other property.</p> <p>e) The contractor shall get a written confirmation either from engineer in-charge or C&M department of BSES in case cross bonding is not applicable for any specific cable route.</p>
--	-----------------------	--

3.0.0 General Guidelines for Laying Cables

3.1.0	General	<p>a) Laying of the cables and handling of the same shall be undertaken, at all times, by adequate staff suitably trained and supplied with all the necessary plant, equipment and tools.</p> <p>b) The contractor shall be responsible for all the route survey, establishment of the position of the joints as per the site exigencies and the drum lengths of cables to be laid. While carrying out the route survey the contractor shall take into account the obstacles on the route whether above or below ground. The cable shall be planned to be laid in an orderly formation, free from unnecessary bends and crossings</p> <p>c) The contractor shall submit a drawing for the complete scheme showing the entire route, road crossings, location of joints and also the arrangement of cables to be laid. In case due to site exigencies, cables have to cross over within the trench, the same shall be shown in the drawing. For each and every job, these drawings shall be approved by BSES, prior to commencement of work.</p> <p>d) BSES shall arrange for all the material and manpower required for jointing and end termination. The Contractor shall provide pit, carry out excavation for creation of</p>
-------	---------	--

		<p>working space required for jointing by the joiner. The contractor shall carry out all civil works, structural work, clamping and earthing, so that the cables and accessories perform satisfactorily during the entire lifetime.</p> <p>e) The entry and exit of the cables into the building shall be through RCC or GI pipe except for single core cables, which shall be properly sealed and shall be duly supported as per the method and technique approved by BSES, so that the outer sheath of the cable does not get damaged at the entry and exit points. The sealing should be of adequate length so that it minimizes the risk of spreading of fire or ingress of water.</p>
3.2.0	Handling and Storage of Cable drums	<p>a) The cable drums shall be transported upright, so that the weight is distributed on both the flanges. Under no circumstances the cable drum may be laid on its side. During transportation the drums must be properly secured. The cable drums should never be dropped from Lorry or a trailer, so as to prevent damage to the cable drum and also to the cable. Ramp may be used for unloading. The drums may be rolled over short distance, provided the correct direction of rolling as provided on the drum is observed. Alternatively, a mobile crane should be used for lifting and lowering the drum. A chain-pulley arrangement may also be used to lift the drums and deposit the same on ground if required.</p>

		<p>b) In case the drums are to be stored prior to cable laying, they should be arranged in such a way to leave some space between them for air circulation. It is desirable that the drums stand on battens placed directly under the flanges. Overhead covering is not essential except in heavy rainfall areas or during monsoon. Cable should however be protected from direct rays of sun by leaving the battens on or by providing some form of sunshade. In no case the drums shall be stored in a flat position with flanges horizontal.</p> <p>c) For transportation of the cable drums from storage site to work site, the drum should be mounted on a trailer or an open lorry and unloaded by mobile cranes.</p>
3.3.0	Cable Laying	<p>a) The ground over which the drum is positioned at site should be properly consolidated and jacks placed on both sides of the drum to make the pay-off arrangement stable. Suitable arrangement be made to stop the drum rotation, during cable laying preferably by square wooden poles kept temporarily pivoted over cable roller under the flanges which when required can be applied on the flange as a brake by personnel manning the drum.</p> <p>b) The cable should always be paid off from the top of the drum. The drum must be positioned in such a way that the arrow on the drum points opposite to the direction of rotation marked on the drum.</p> <p>c) It must be ensured that the cable is not dragged over sharp object or on the road surface, so as to avoid damage to the outer sheath of the cable.</p> <p>d) The pulling method to be used shall be approved by BSES. Cable supplier's recommended maximum pulling tension shall not be exceeded.</p> <p>e) Rollers shall be placed at intervals and the cable shall be pulled over the rollers. The rollers shall be kept lubricated so that they rotate freely, minimize friction to the cable in motion. Rollers shall be positioned at the bends to minimize sidewall friction. The contractor shall ensure that PVC/HDPE sheath of cable is free from damage due to</p>

		<p>abrasion.</p> <p>f) The cable should not be pulled out from the drum by lifting of the coil while the drum is lying flat on the flange. This leads to twisting of the armour and cores resulting in permanent damage to the cable.</p> <p>g) To avoid ingress of moisture, it must be observed that the end capping of the cables is not damaged. Cut pieces of the cables must be capped immediately, before laying of the same is taken-up.</p>
3.4.0	Excavation of the Trenches	<p>a) The excavation of the trenches shall be commenced, with proper co-ordination with BSES, so that all the necessary clearances for the route are already obtained from the competent authorities, well in time.</p> <p>b) Before opening of the section of the trench, the contractor shall satisfy himself that the line of the trench is clear of underground obstructions, by taking out trial pits on the line of the trench.</p> <p>c) The exact location of each trench shall be approved on site by BSES. The trenches shall be kept as straight as possible and each trench shall be excavated to approved formation and dimensions. If necessary, the trenches shall be adequate shored by wooden planks and bracing to avoid trench cave-ins which would cause injury to the persons and also damage the cables laid.</p> <p>d) The bottom of each trench shall be firm and of smooth contour. The contractor shall take reasonable precautions to prevent damage to the highway or ground surface from a slip or breaking away of the sides of the trench.</p> <p>e) The trench excavation and filling in shall be so executed that all walls, roads, sewers, drains, pipes, cables, structures, places and things shall be reasonably secured against risk of subsidence or injury and shall be carried out to the satisfaction of the authorities concerned. Should, however, a damage to an existing or other services be made, the Contractor will arrange and pay for any necessary repair, to make good the damages.</p> <p>f) Where trenches pass from a footway to a roadway or at</p>

		<p>other positions where a change of level is necessary, the bottom of the trench shall rise or fall gradually. The rate of rise or fall shall be approved by BSES.</p> <p>g) Contractor shall ensure that during excavation and until restoration has been completed, for reasonable access of persons and vehicles to property or places adjacent to the route.</p> <p>h) When the excavation of the trenches has been accurately executed, the contractor shall inform BSES for approval. Laying of cables or building of structure shall not be started until the contractor has been advised by BSES to proceed with the work.</p>
3.5.0	Excavated material	<p>a) The materials excavated from each trench shall be placed so as to prevent nuisance or damage to adjacent ditches, drains fences, gateways and other property or things. Excavated material shall be stacked so as to avoid undue interference with traffic.</p> <p>b) Where, owing to traffic or for reasons of safety or other considerations, this is not permissible, the excavated material shall be removed from the site and returned for refilling the trench on completion of laying; surplus material shall be disposed off by the contractor at his own cost.</p>
3.6.0	Pipes and Ducts	<p>a) Care shall be taken to make the bend of the pipes or duct lines as easy as practicable and in no case of radius less than 3 meters. Where approved, split pipes may be used on bends, the pipes being fitted round the cable after laying.</p> <p>b) All road crossings shall be ducted. This applies to present and future roads as indicated on the route plans. The pipes and the ducts shall be laid in an approved manner and shall be surrounded by 150 mm of PCC (1:2:4)</p> <p>c) Ducts under the road shall be provided by the contractor, by non-disruptive method, if road cutting is not permitted by the concerned authorities Cable laying shall be done by Horizontal Direct drilling method (HDD).</p> <p>d) The cables shall be suitably protected at entry and exit from the pipes, so that the outer sheath does not come in</p>

		<p>contact with the edges of the pipes / ducts. The pipes and ducts shall have slope so that the seepage water can drain through the small opening provided on the lower side of the pipe sealing.</p> <p>e) The pipes and ducts shall be secured to the base at both ends and at regular interval, throughout the length, so that at no point the ducts or pipes get suspended over the threaded cable, and damage the same, thus defeating the very purpose of providing the pipe / duct.</p> <p>f) At all road crossings at least one spare duct / pipe shall be provided for future use. The pipe shall be thoroughly cleaned of obstructions. A draw wire or rope shall be left in each pipe to facilitate the drawing in of the cables. The duct end shall be sealed temporarily to prevent the entry of foreign matter. End caps and permanent markers shall be placed flush with footpath / roadways at both the ends. The pipes and ducts shall be cleaned again immediately before the cables are drawn in.</p> <p>g) The internal diameter of the pipe / duct should be such that the cables occupy only 40% of the area of the pipe / duct to avoid de-rating.</p>
3.7.0	Joint / cross bonding bays	<p>The contractor shall provide all help so as to enable jointers to carry out their work efficiently and expeditiously. The method of securing and supporting cable joints and cables also the bonding and earthing thereof, shall be detailed on the drawing. The details shall be approved by BSES prior to commencement of work. The joint position should be staggered.</p>
3.8.0	Back filling trenches and temporary Reinstatement	<p>a) Filling in of trenches shall not be commenced until BSES has inspected and approved the cables and accessories at site. The inspection should be carried out on daily basis so that the trenches do not remain open unnecessarily, to avoid inconvenience to public.</p> <p>b) Where cables routes are in public highways, footpaths, gardens etc., the method of reinstatement will be subject to approval by MCD. All costs incurred will be at the contractor's expenses.</p>

		<p>c) The contractor shall be responsible for proper permanent reinstatement of the upper levels, which shall be carried out to the satisfaction of BSES and the MCD authorities concerned.</p> <p>d) Before finally leaving site, permanent reinstatement shall be executed by the contractor to the approval of MCD and the property owners and all costs incurred shall be to the contractor's account.</p>
3.9.0	Permanent Reinstatement of Public Road, foot path & ground in private property.	<p>a) In public roads and footways the surfaces and foundations shall be temporarily reinstated by the contractor. After settlement, temporary reinstatement material shall be removed as necessary and the permanent reinstatement shall be carried out to the approval of the appropriate highway authority / MCD. Stone and pre-cast concrete paving kerbs and channels shall also be finally reinstated by the contractor.</p> <p>b) Temporary reinstatement shall be maintained by the contractor until commencement of final reinstatement to ensure that the surface is always safe for the passage of pedestrians and vehicular traffic.</p>
3.10.0	Identification	All cables shall be identified below the gland at each end, at joint position and at approved positions by means of bands engraved or punched with cable no. feeder name, size of cable, number of cores, phase colour etc. The bands shall be secured fastened in a permanent manner, and shall be made of material able to resist corrosion, dampness and mechanical damage.
3.11.0	Cable Route Markers	All cables routes shall have markers at suitable location with a gap not exceeding 30 meters. The route markers shall be approved design. Additional markers shall be provided at joint locations with approved markings.
3.12.0	Cable supports / Clamps	a) The contractor shall supply and install all the supports, racks, trays, cleats, saddles, clips and other parts required to carry and secure the cables, without risk so that there is no undue mechanical load or stress due to weight of the cable at each end. Cleats, saddles and clips shall be of the

		<p>design as approved by BSES. No cable shall be laid on the trench floor. They shall be run in a neat and orderly manner and the crossing of cables within the trench shall be avoided as far as possible. Where cable runs unavoidably cross, a suitable supporting arrangement shall be provided to maintain an adequate gap between the cables</p> <p>b) Every cable shall be supported at a point not more than 500 mm from its termination.</p>
3.13.0	Installation of Cables in tunnels / basement / below the panels etc	<p>a) The design of cable support for cables installed in air in cable tunnels, basements etc. shall consist of vertical steel members spaced at approved interval and secured to the walls, floors and ceilings as necessary by means of bolts either cemented in position or expanded into cored holes. Each vertical support shall have bolted to it a number of steel brackets spaced at the intervals and designed to support and retain trays constructed of galvanized sheet steel of adequate section to carry the weight of the cables, plus space for an additional quantity of future cables at least 25% by weight and dimensions in excess of the cables installed under the contract and an additional load of 100 kg at the extremity without distortion. The trays shall be designed with raised edges to retain the cables and shall incorporate an interlocking feature so as to prevent movement between supports.</p> <p>b) The design and construction of all cable cleating and supporting arrangements shall suit the cable system design. The spacing of cable supports shall be approved by BSES.</p> <p>c) Cable run on trays shall be neatly dressed and where not provided with cleats shall be secured by heavy gauge, type approved metal reinforced, clips or saddles. Not more than six cables shall be embraced by one clip.</p> <p>d) Mild steel of appropriate sections, duly painted in an approved manner, shall be used for fabrication of cable supports. The steel shall be free from blisters, scales, laminations or other defects. Before final painting, the steel</p>

		sections shall be provided with double coat of red primer.
3.14.0	Cable Protection at overhead Towers or Poles	Where the cables terminate on overhead line poles or towers located outside substation compounds the contractor shall provide suitable cable supporting galvanized steel work attached to the pole or tower and comprising backboard, runners, sheet, steel cover of not less than 3.0mm thickness, stays, cable cleats, anti climbing guard and all incidental items to provide secure protection for the cables. Isolators and Lightning arrester if required to be installed shall be provided as free issue item to the contractor, however the erection and steel structure required shall be in scope of the contractor.
3.15.0	Sun Shades	All cables shall be protected from direct solar radiation by ventilated sun shields as approved by BSES.
3.16.0	Route Plan	<p>a) BSES intends to show all the cable routes, location of joints and other underground obstructions on a GPS map.</p> <p>b) During the progress of the contract works the contractor shall record on a set of route plans and cross section drawings of an approved form, these details so that the same can be transferred on the GPS maps. Such particulars will allow an accurate reference to be made in the case of any fault or projected modification. These records shall show, amongst other data, both indoors and outdoors the exact position of every joint, cable end termination and also the particulars of the depth of the trench, the arrangement of the cables, with cable numbers and the position of all obstructions revealed during the course of excavations. These completed records shall be submitted to BSES within 15 days of completion of any particular route/feeder. The final bill shall not be processed by BSES unless this activity has been completed to the entire satisfaction of BSES</p>
3.17.0	Site Facilities to be maintained by the Contractor	<p>a) The contractor shall arrange for all the tools and tackles required for cable laying as per this specification. BSES shall arrange for all the material and manpower required for jointing and end termination.</p> <p>b) The contractor shall arrange illumination and Power supply</p>

		<p>so that the work can be carried out round the clock.</p> <p>c) The contractor shall maintain functional dewatering pumping facility with suitable power supply so as to protect the cables and the joints from ingress of water due to rain or otherwise</p> <p>d) The contractor shall make arrangement to provide suitable scaffolding arrangement to carry out the termination work</p> <p>e) The contractor shall carry out proper barricading of the dug cable route and the joint bays and shall take all necessary precautions to avoid any public hazard</p>
3.18.0	Type of Roads and guidelines for road restoration	<p>The typical section of type of Roads (based on width) under PWD and MCD are:-</p> <ul style="list-style-type: none"> - 20 Feet Wide road - 30 Feet wide road - 40 to 60 Feet Road - Other (which include Kota stone, Agra stone, Cement concrete, interlocking paving tiles, brick road, chequered tiles and asphalted road) <p>The drawing are shown in annexure IV</p> <p>The guidelines for road restoration for various type of roads and surfaces are indicated in annexure V as :-</p> <ul style="list-style-type: none"> - Bituminous road Type I (category I & II) - Bituminous road Type II (category III) - Cement concrete road - Kota/Rajasthan stone Road - Brick Road - Interlocking paving tiles. - Agra stone road - Chequered tiles road - Asphalted road

4.0.0 Testing

4.1.0	Tests to be carried out during and after completion of	<p>Testing of cable before jointing –</p> <ul style="list-style-type: none"> - Cable shall be tested for Insulation Resistance prior to laying by opening the end and resealing end properly.
-------	--	--

	Cable Laying	<p>Testing on complete Cable Installation –</p> <p>a) Insulation resistance of each core shall be measured against all the other cores and the metal screen connected to earth.</p> <p>b) The resistance of the conductor shall be measured.</p> <p>c) Low frequency AC test – 66KV / 33KV Cable shall only be subjected low frequency AC test. DC Test is not acceptable.</p> <p>d) DC High voltage. For old cables test voltage shall be 1.5 times rated AC Phase voltage or less depending on age of cable.(refer annexure # 2 for values)</p> <p>e) Charging of Cable at No-Load at Nominal working voltage for 24 Hours.</p> <p>f) After laying and before termination of cable a sheath test shall be conducted for 66KV Single core Cable as under:- At both ends the cable shall be raised from ground. From the end graphite coat applied over the outer HDPE / PVC jacket shall be removed with a piece of glass for a length of 300mm. A spiked steel rod with an eye for attaching a wire shall be driven into the ground and connected to a nearby water or hydrant pipe. Insulation resistance of PVC jacket shall be measured between the aluminum wire armour and the spike with a 500/1000V insulation tester. Measured resistance shall not be less than 2.5M OHM per KM. Thereafter 10KV DC shall be applied for one minute in the same way. After the test the armour shall be kept earthed to the steel spike for 15 minutes for discharging residual charge.</p>
--	--------------	--

5.0.0 Progress Reporting

5.1.0	Detailed Progress report	<p>Progress report to be submitted by Contractor to BSES once in a Week containing</p> <p>i) Excavation status</p> <p>ii) Cable laying status</p> <p>iii) Status of preparedness for Jointing</p> <p>iv) Reason for any delay in total programme</p> <p>v) Details of damage to cable during laying.</p>
-------	--------------------------	--

		vi) Progress on final completion / Constraints / Forward path
--	--	---

6.0.0 Drawing, Data & manuals

6.1.0	To be submitted after Completion of the Job	<p>As the works is completed the following reports in quadruplicate shall be submitted to BSES for record purpose and shall be incorporated in the 'As constructed Records'.</p> <p>a) Feeder details (sending end, receiving end, SAP number of project etc)</p> <ul style="list-style-type: none"> - Type of cables, cross section area, rated voltage. Details of construction, cable number & drum number. - Year and month of laying. - Actual total route length, cable length, length between joint to joints or end. - Location of cables and joints in relation to certain fixed reference points, for example buildings, hydrant, boundary stones etc. - Jointing reports detailing the date, weather conditions, jointers and supervising Engineers names, details of type of cable and type of joint or termination, location and joint bay number, ambient temperature. - Results of original electrical measurements and testing on cable installation. - Full written reports will be required of any damage occurring to cable or equipment together with remedial action proposed which will be subject to the approval of BSES.
6.2.0	Drawing and document sizes	Standard size paper A0, A1, A2, A3, A4

7.0.0 Deviations

Deviations from this Specification shall be stated in writing by the contractor. Written approval shall be obtained from BSES by the contractor. In absence of such a statement, it will be assumed by BSES that the Contractor complies fully with this specification during execution of the job. The format for approval of deviation attached in annexure # 1

Annexure # 1 – DEVIATION REPORT FORMAT

S No	Clause no of Specification	Details about deviation	Reason for Deviation	Approved by (Signature / Name)

Annexure # 2 – DC HIGH VOLTAGE TEST

Rated Voltage of cable in KV	Test Voltage Between		Duration in Min.
	Any conductor and metallic sheath / Screen / armour	Conductor to conductor (for unscreened Cables)	
0.65 / 1.1	3	3	15
6.35 / 11	18	30	
19 / 33	NA	----	
38 / 66	NA	----	

Reference value for DC High voltage Test.

Annexure # 3 – CABLE TRENCH TYPE**Cable Trench Details**

Sr. No	Cable Size	Trench		Cable Trench Type
		Width	Depth	
		MM	MM	
1	1.1 KV LT Cables			
a	3.5Cx150 mm ² - Single Circuit	400	875	A – 1 (Drg. # 9)
b	3.5Cx150 mm ² - Double Circuit			
c	3.5Cx150 mm ² - Triple Circuit			
d	3.5Cx300 mm ² - Single Circuit	400	875	A – 1 (Drg. # 8)
e	3.5Cx300 mm ² - Double Circuit			
f	3.5Cx300 mm ² - Triple Circuit			
2	11 KV Cables			
a	3Cx150 / 300 mm ² - Single Circuit	400	1055	A – 2 (Drg. # 6)
b	3Cx150 / 300 mm ² -Double Circuit	600	1055	B – 1 (Drg. # 7)
3	33 KV Cables			
a	3Cx400 mm ² - Single Circuit	400	1235	A – 3 (Drg. # 3)
b	3Cx400 mm ² - Double Circuit	650	1235	B – 2 (Drg. # 4)
c – 1	3Cx400 mm ² - Quadruple Circuit	650	1235	B – 2 (Drg. # 5A)
c – 2	3Cx400 mm ² - Quadruple Circuit	650	1545	B – 3 (Drg. # 5B)
c - 3	3Cx400 mm ² - Quadruple Circuit	1200	1235	C – 1 (Drg. # 5C)
4	66 KV Cables			
a	1Cx630/1000 mm ² - Single Circuit	650	1445	B – 4 (Drg. # 1)
b	1Cx630/1000 mm ² - Double circuit	1200	1445	C – 2 (Drg. # 2)

Annexure # 4 – STANDARD ROAD PROFILE

**STANDARD ROAD PROFILE
20' - 00 " FEET WIDE ROAD (Road type 1)**

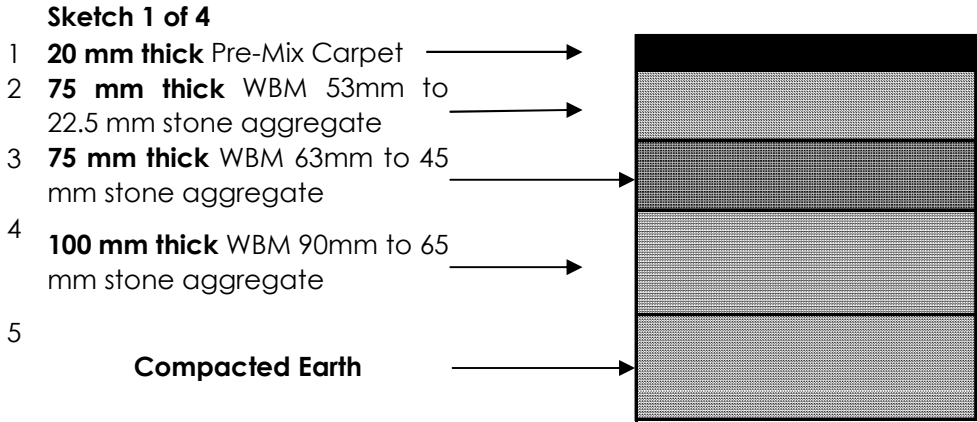

Sketch 2 of 4 30' - 00 " FEET WIDE ROAD (ROAD TYPE II)

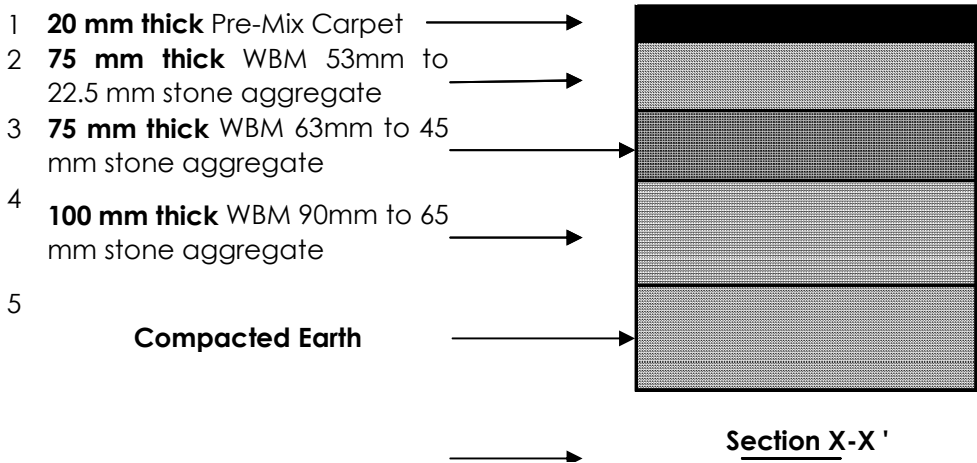

Sketch 3 of 4

40'-00" TO 60'-00" FEET WIDE ROAD

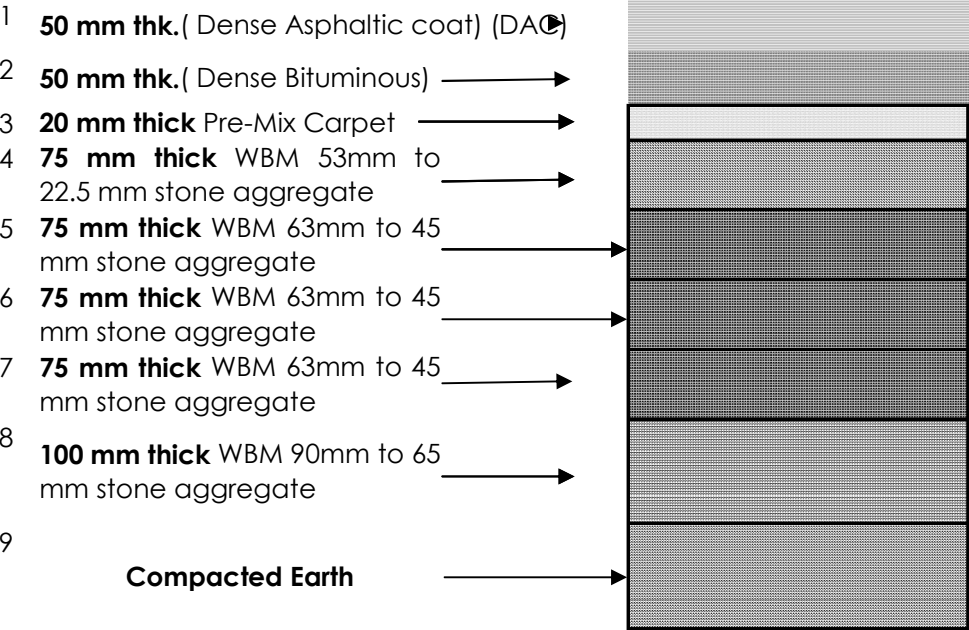

Section A-A'

Sketch 4 of 4

General drawing for cases other than roads.

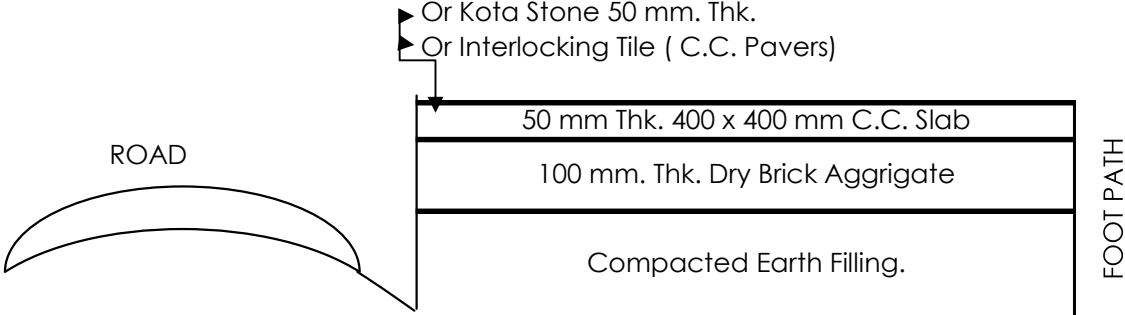

Details of Foot Path Along roads under PWD & MCD.

Annexure # 5 – ROAD RESTORATION SECTIONAL DRAWINGS

ROAD RESTORATION SECTIONAL DRAWINGS

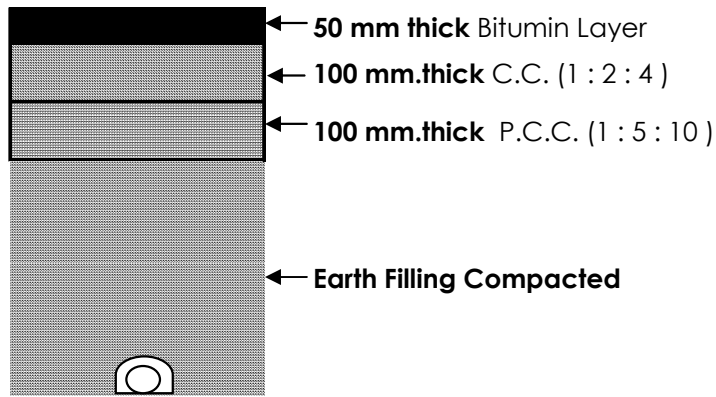

Bituminous Road Type - I (Category 1 & 2) Road width 20 to 30 feet and 30 to 40 feet.

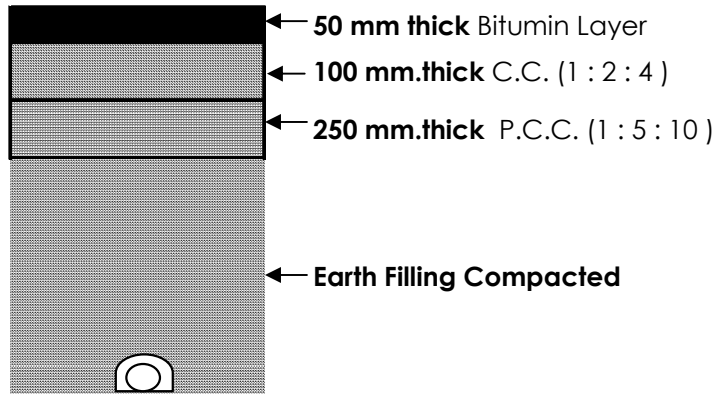

Bituminous Road Type - II (Category 3)

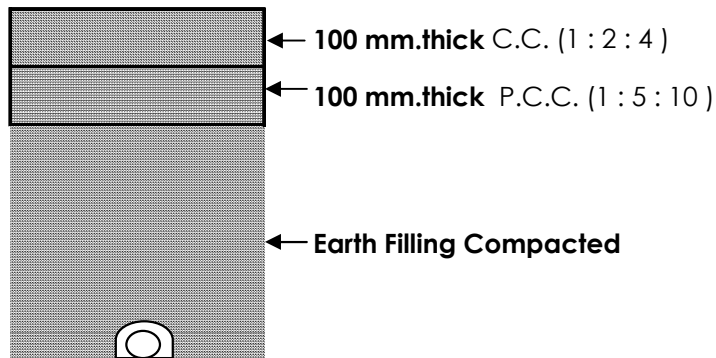

Cement Concrete Road

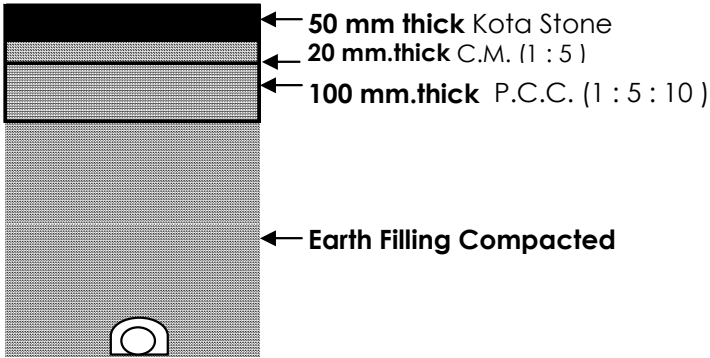

Kota / Rajasthan stone Road

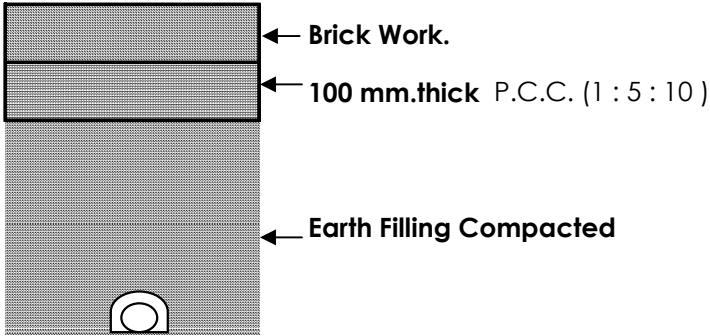

Brick Road

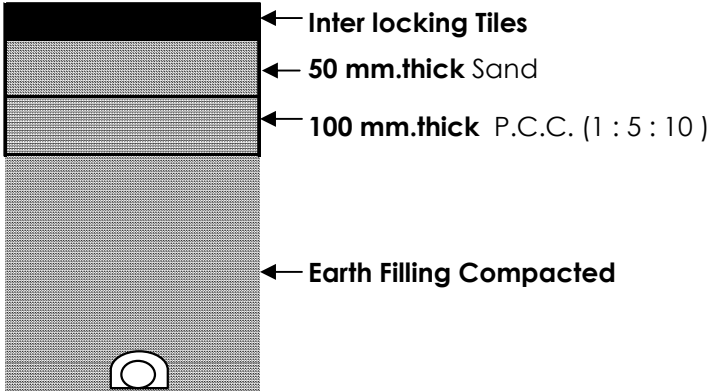

Interlocking Paving Tiles

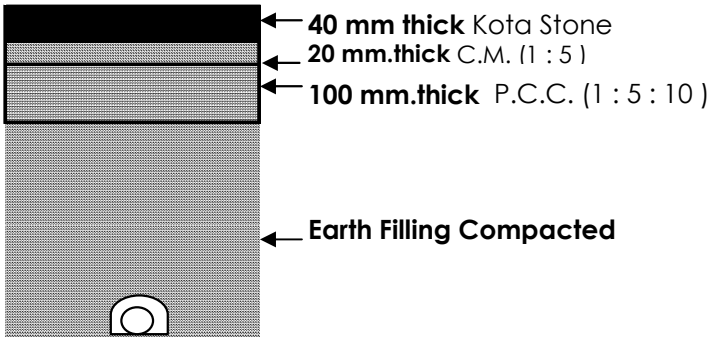

Agra stone Road .

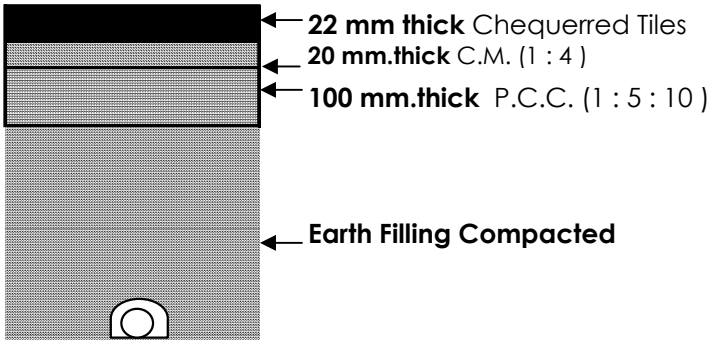

Chequerred Tiles .

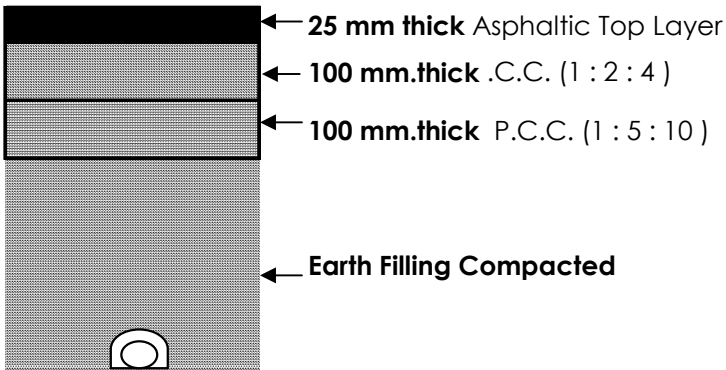

Asphaltic Road .

DRAWING # 1

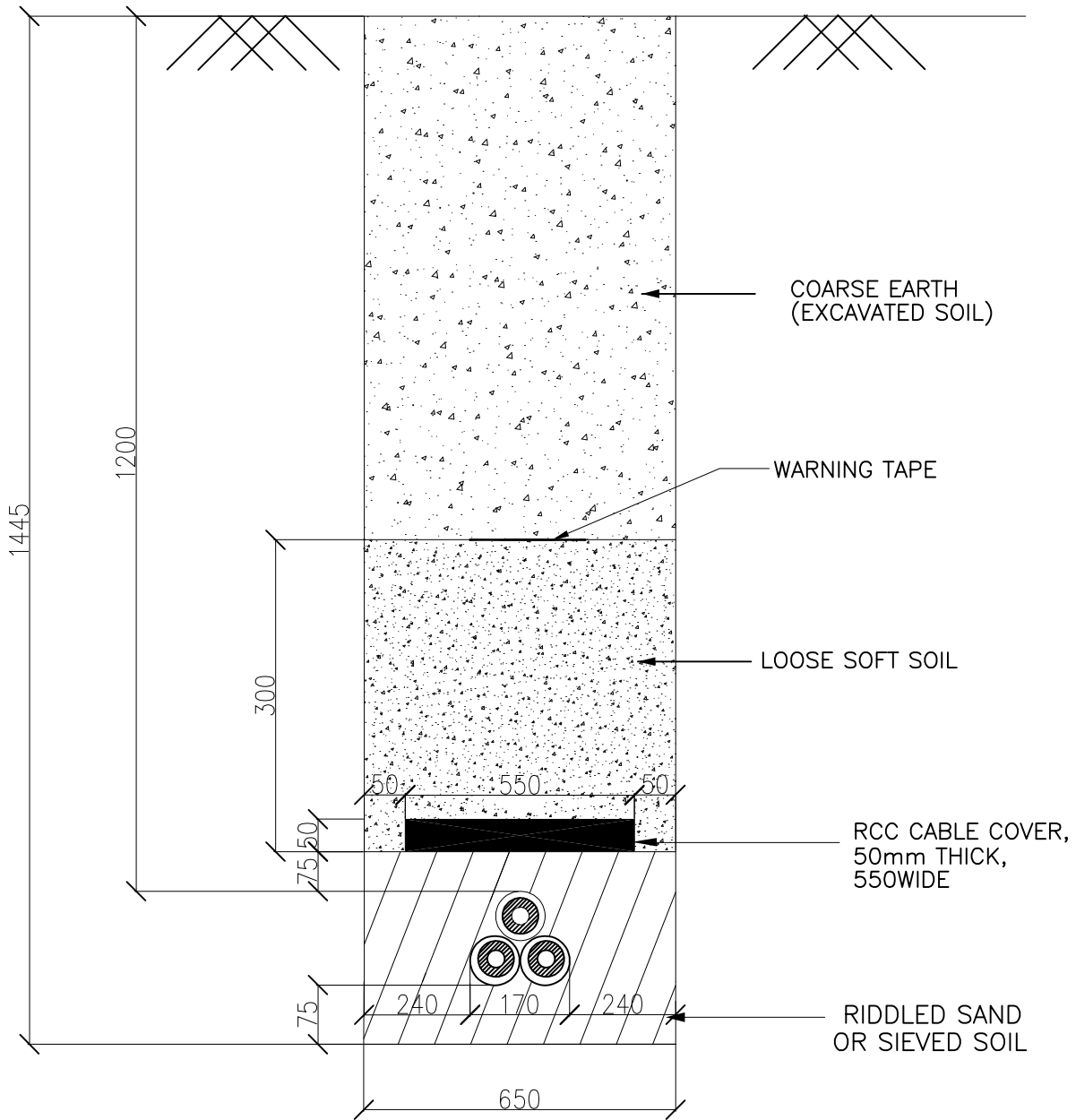

TYPICAL DETAILS FOR 66KV BURIED CABLE FOR SINGLE CIRCUIT
TYPE – B 4

DRAWN	DS	TITLE:-
CHECKED	SGD	TRENCH DRAWING FOR
APPD.	D.GUHA	1C X 630 Sq. mm
DATE		66KV SINGLE CIRCUIT
SCALE		XLPE CABLE

BSES

REV.
00

DRAWING # 2

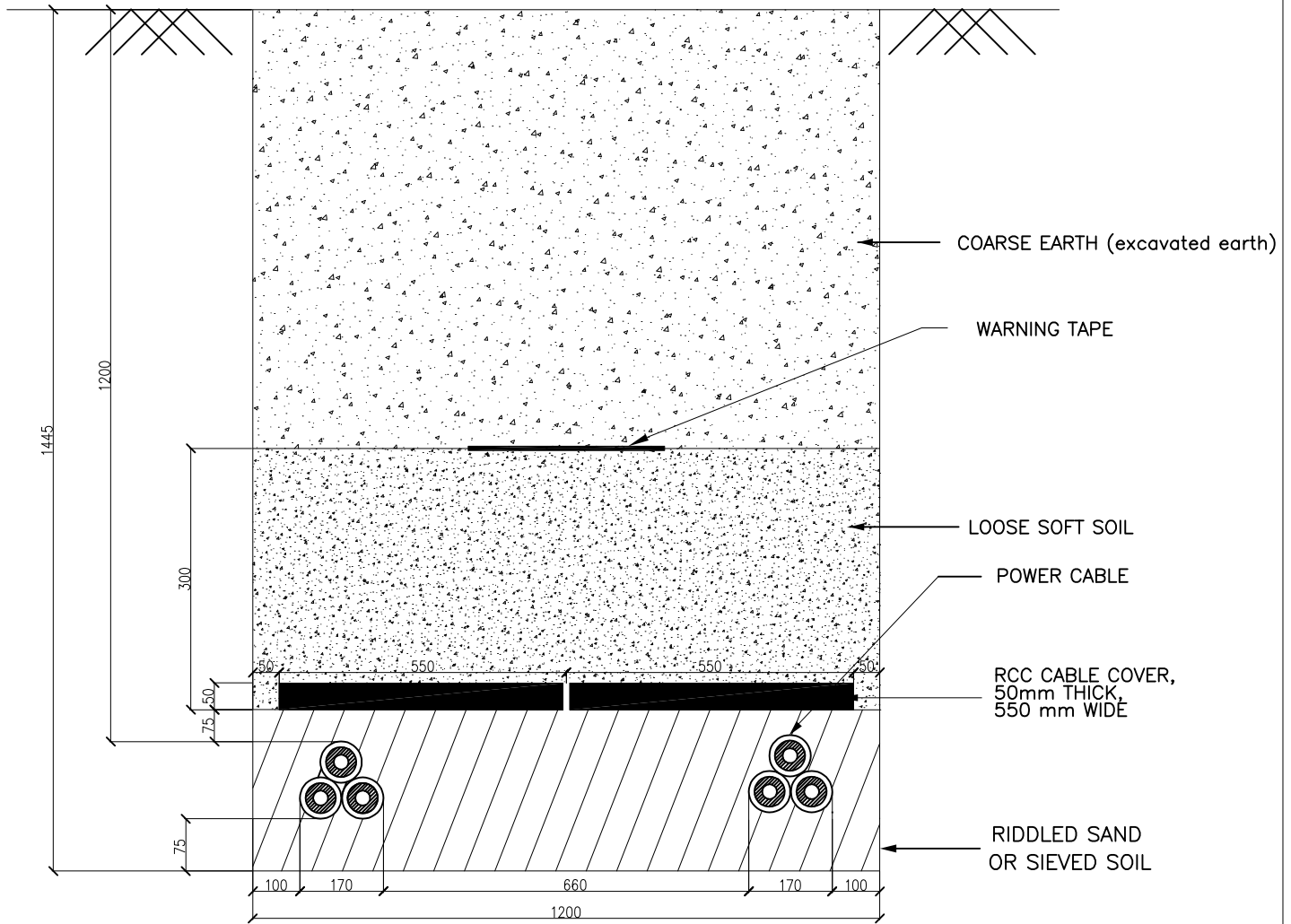

TYPICAL DETAILS FOR 66KV BURIED CABLE FOR TWO CIRCUIT
TYPE – C 2

DRAWN	DS	TITLE:- TRENCH DRAWING FOR 1C X 630 Sq. mm 66KV DOUBLE CIRCUIT XLPE CABLE	BSES
CHECKED	SGD		
APPD.	D.GUHA		
DATE			
SCALE			
			REV. 00

DRAWING # 3

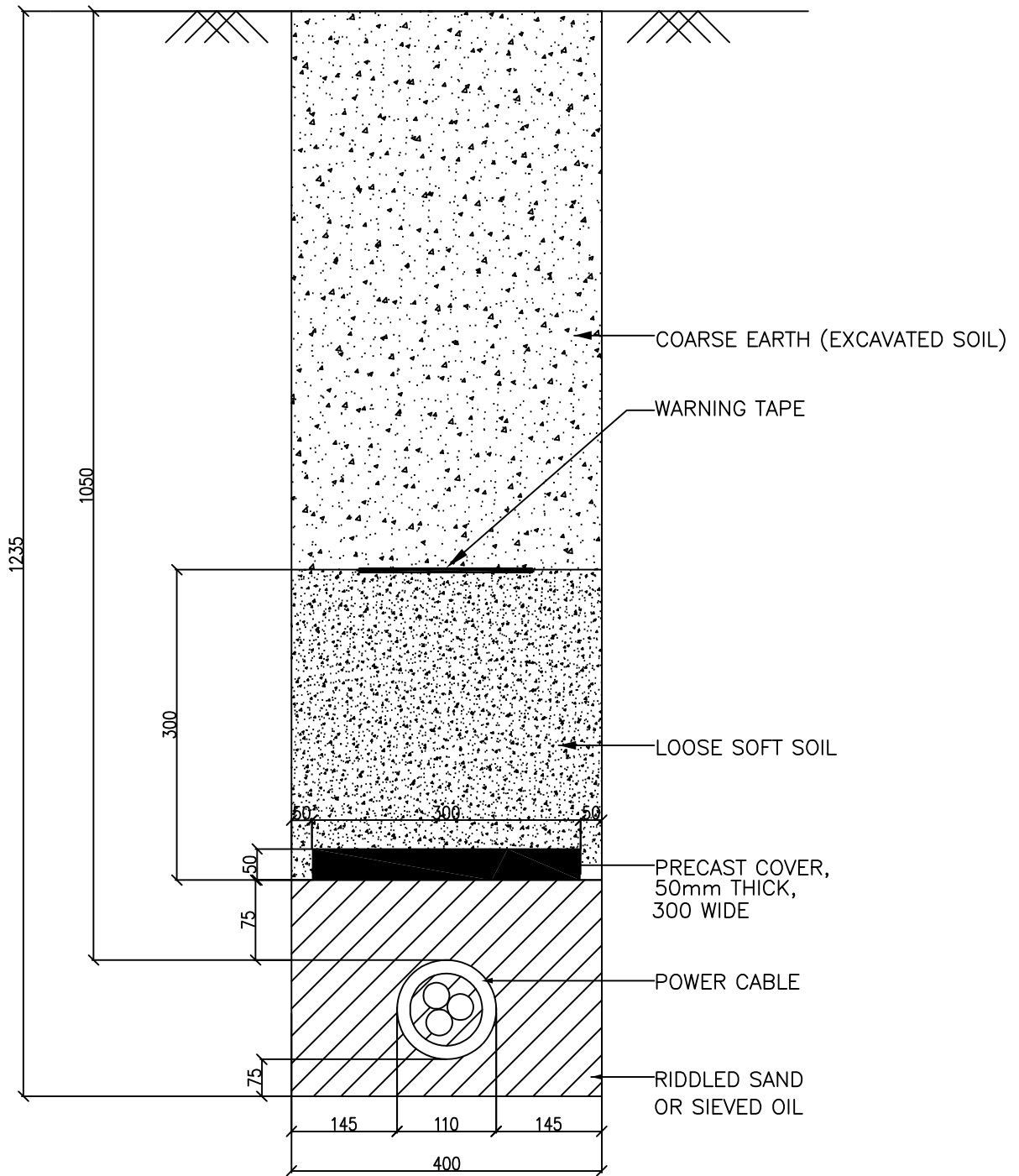

TYPICAL DETAILS FOR 33KV BURIED CABLE FOR SINGLE CIRCUIT
TYPE - A 4

DRAWN	DS	TITLE:-
CHECKED	SGD	TRENCH DRAWING FOR
APPD.	D.GUHA	33KV 3CX 400 mm sq.
DATE		SINGLE CIRCUIT
SCALE		XLPE CABLE

BSES

REV.
00

DRAWING # 4

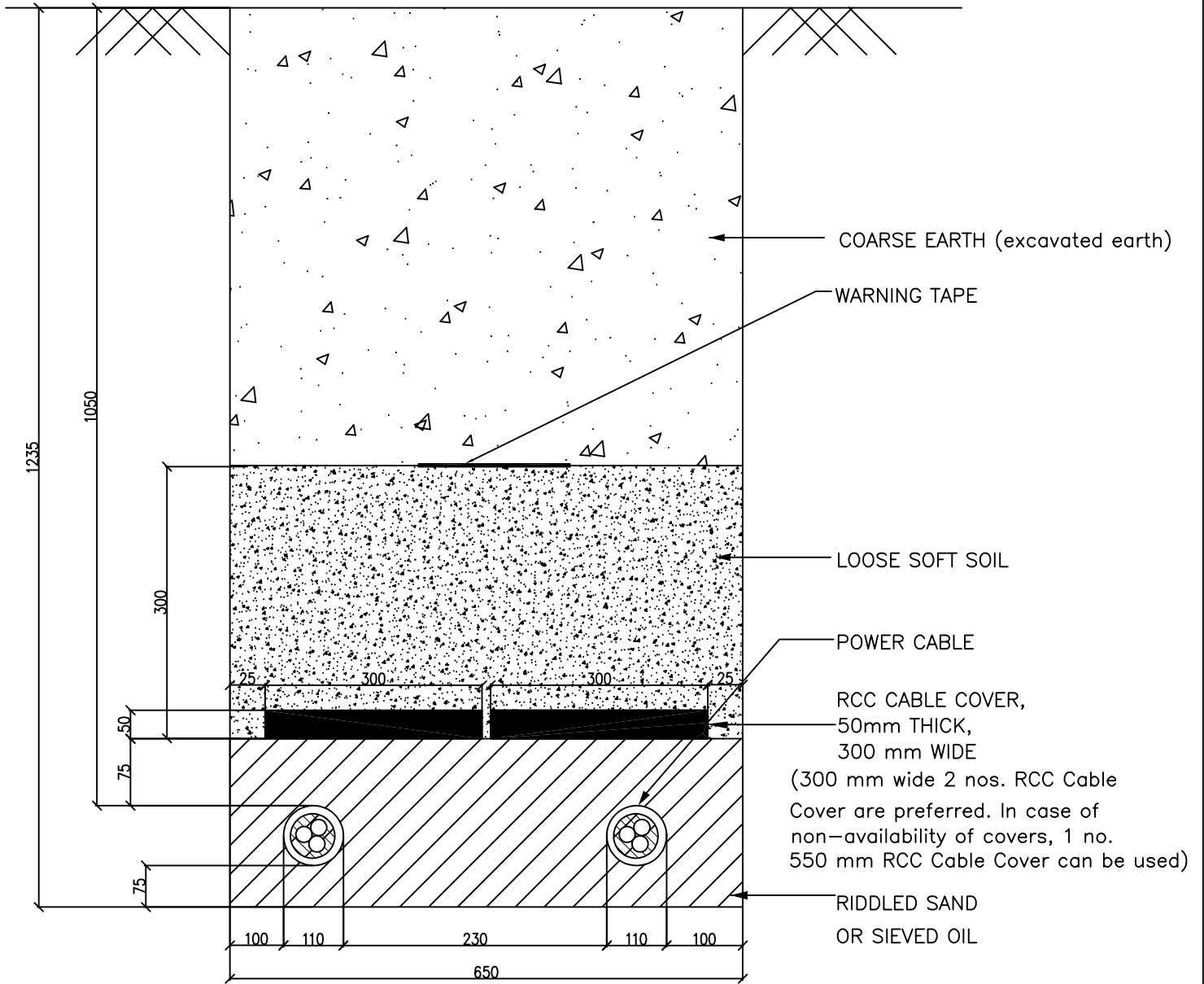

TYPICAL DETAILS FOR 33KV BURRIED CABLE FOR TWO CIRCUIT
TYPE - B-2

DRAWN	DS	TITLE:- TRENCH DRAWING FOR 3C X 400MM ² , 33KV DOUBLE CIRCUIT XLPE CABLE
CHECKED	SGD	
APPD.	D.GUHA	
DATE		
SCALE		

BSES

REV.
00

DRAWING # 5 A

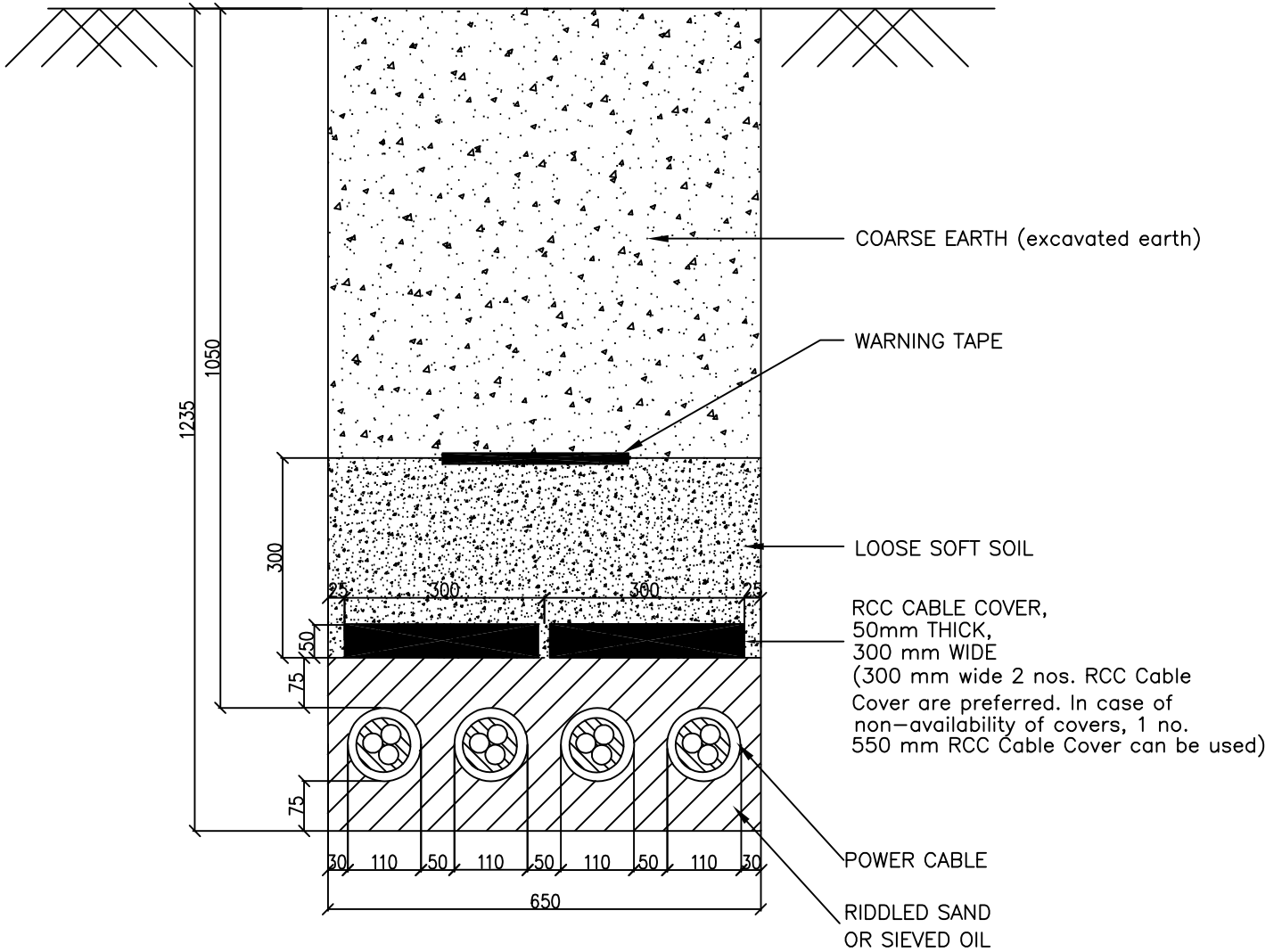

TYPICAL DETAILS FOR 33KV BURIED CABLE FOR FOUR CIRCUIT
TYPE - B 2

DRAWN	DS	TITLE:- TRENCH DRAWING FOR 3C X 400MM ² , 33KV FOUR CIRCUIT XLPE CABLE	BSES	
CHECKED	SGD			
APPD.	D.GUHA			
DATE				
SCALE				REV. 00

DRAWING # 5 B

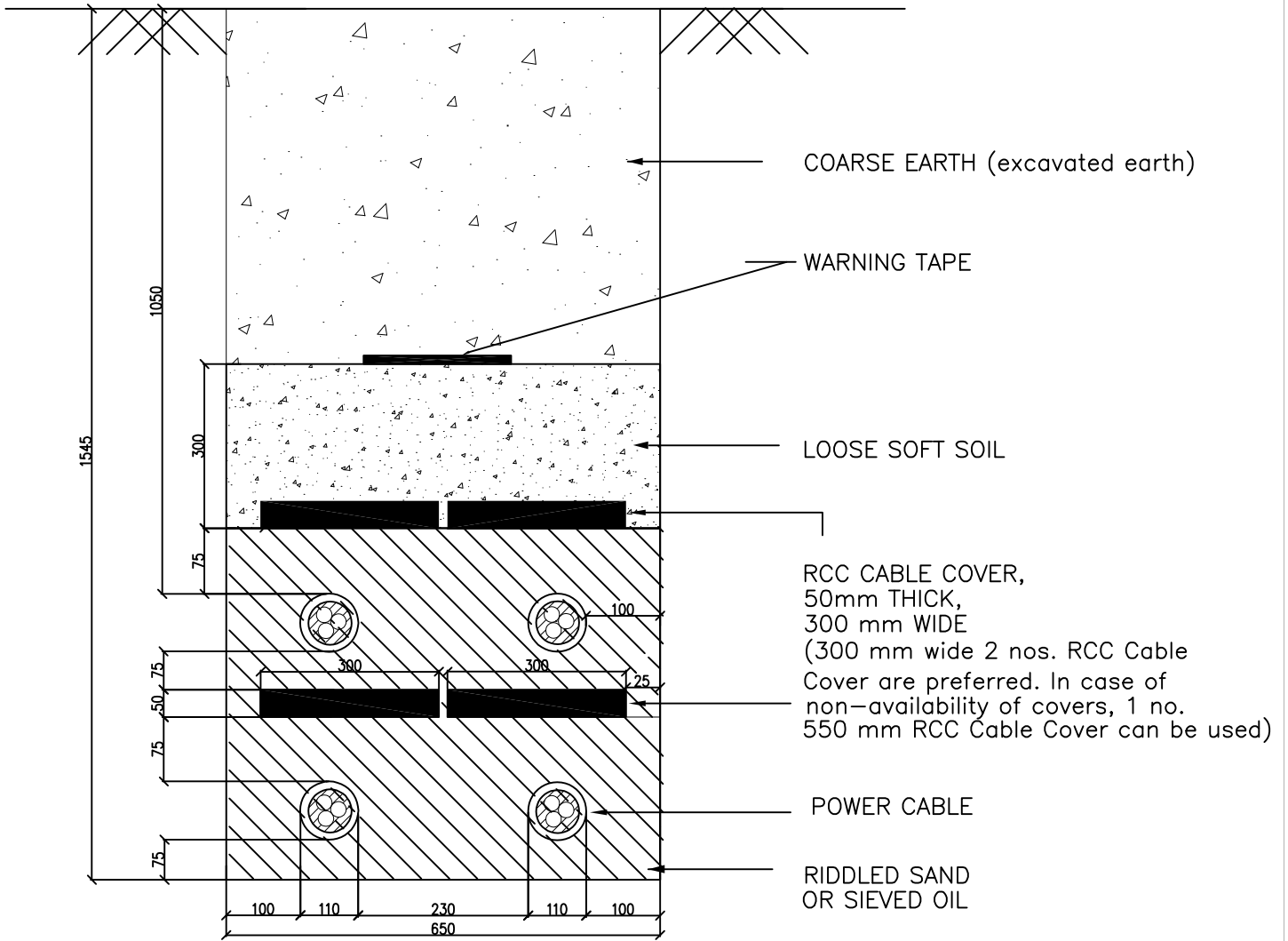

TYPICAL DETAILS FOR 33KV BURRIED CABLE FOR FOUR CIRCUIT
TYPE – B 3

DRAWN	DS	TITLE:--
CHECKED	SGD	TRENCH DRAWING FOR
APPD.	D.GUHA	3C X 400MM2, 33KV
DATE		FOUR CIRCUIT
SCALE		XLPE CABLE

BSES

REV.
00

DRAWING # 5 C

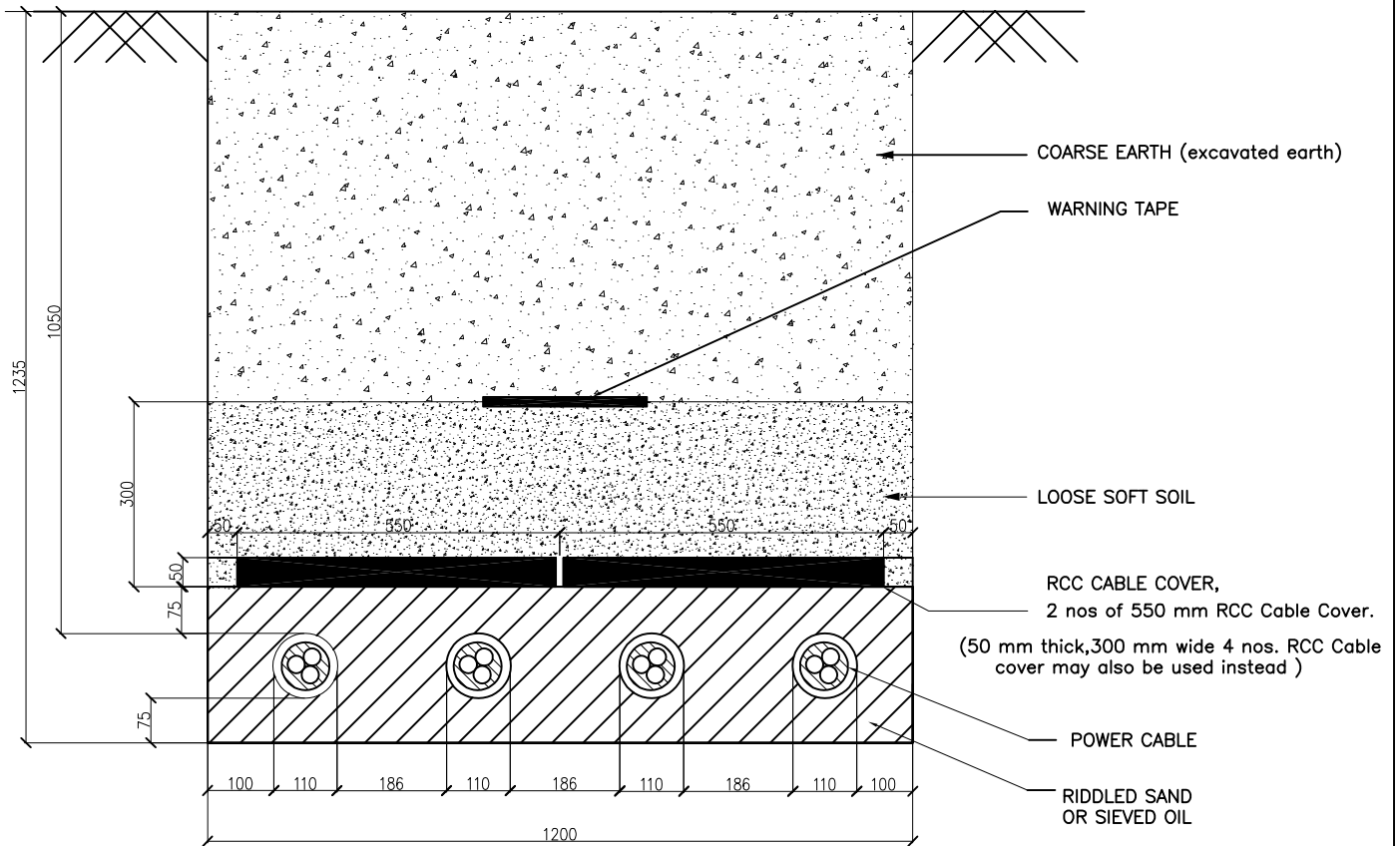

TYPICAL DETAILS FOR 33KV BURIED CABLE FOR FOUR CIRCUIT
TYPE – C 1

DRAWN	DS	TITLE:–
CHECKED	SGD	TRENCH DRAWING FOR
APPD.	D.GUHA	3C X 400MM2, 33KV
DATE		FOUR CIRCUIT
SCALE		XLPE CABLE

BSES

REV.
00

DRAWING # 6

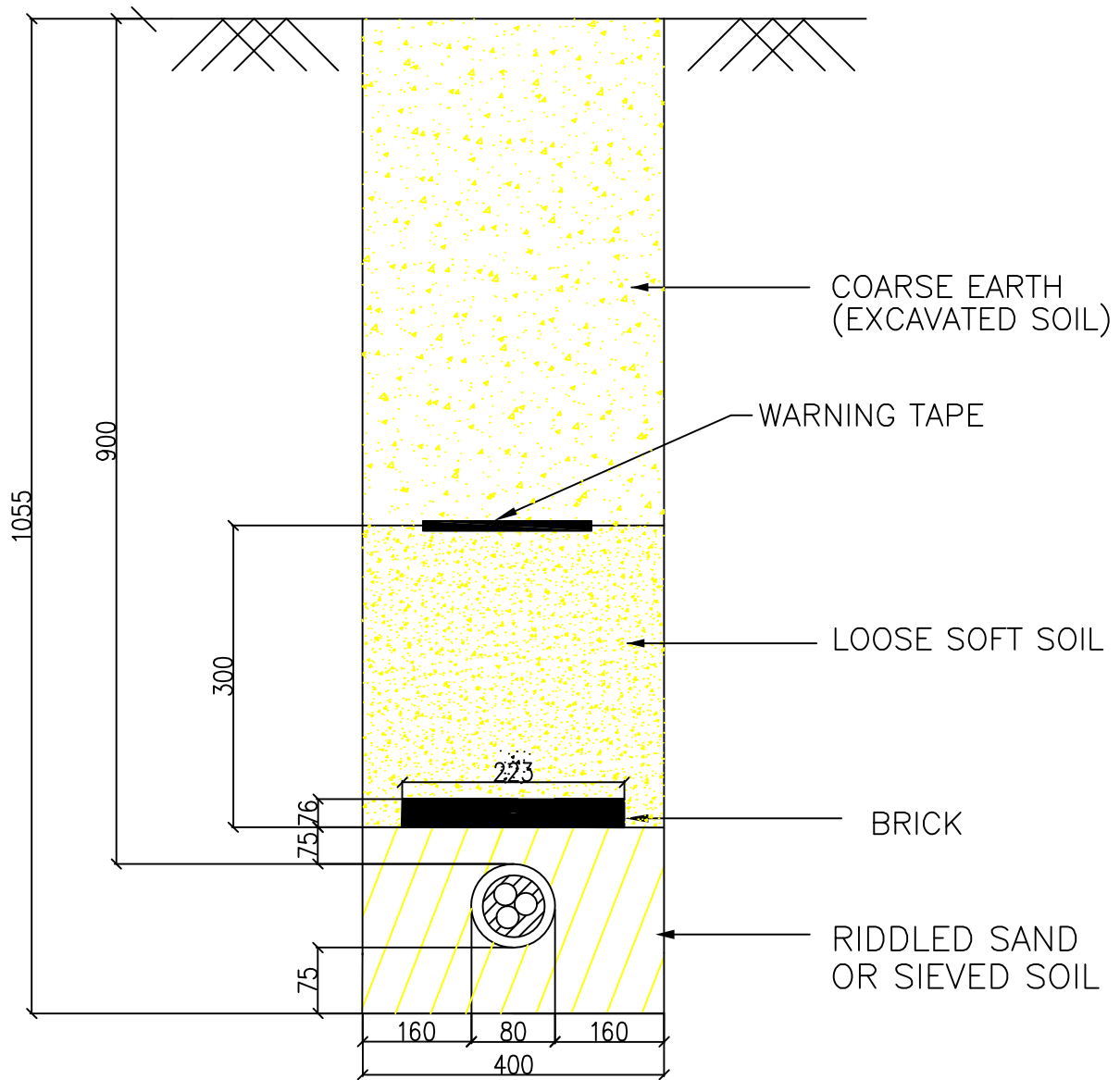

TYPICAL DETAILS FOR 11KV BURIED CABLE FOR SINGLE CIRCUIT
TYPE – A 2

DRAWN	DS	TITLE:-
CHECKED	SGD	TRENCH DRAWING FOR
APPD.	D.GUHA	3C X 300 Sq. mm
DATE		11KVSINGLE CIRCUIT
SCALE		XLPE CABLE

BSES

REV.
00

DRAWING # 7

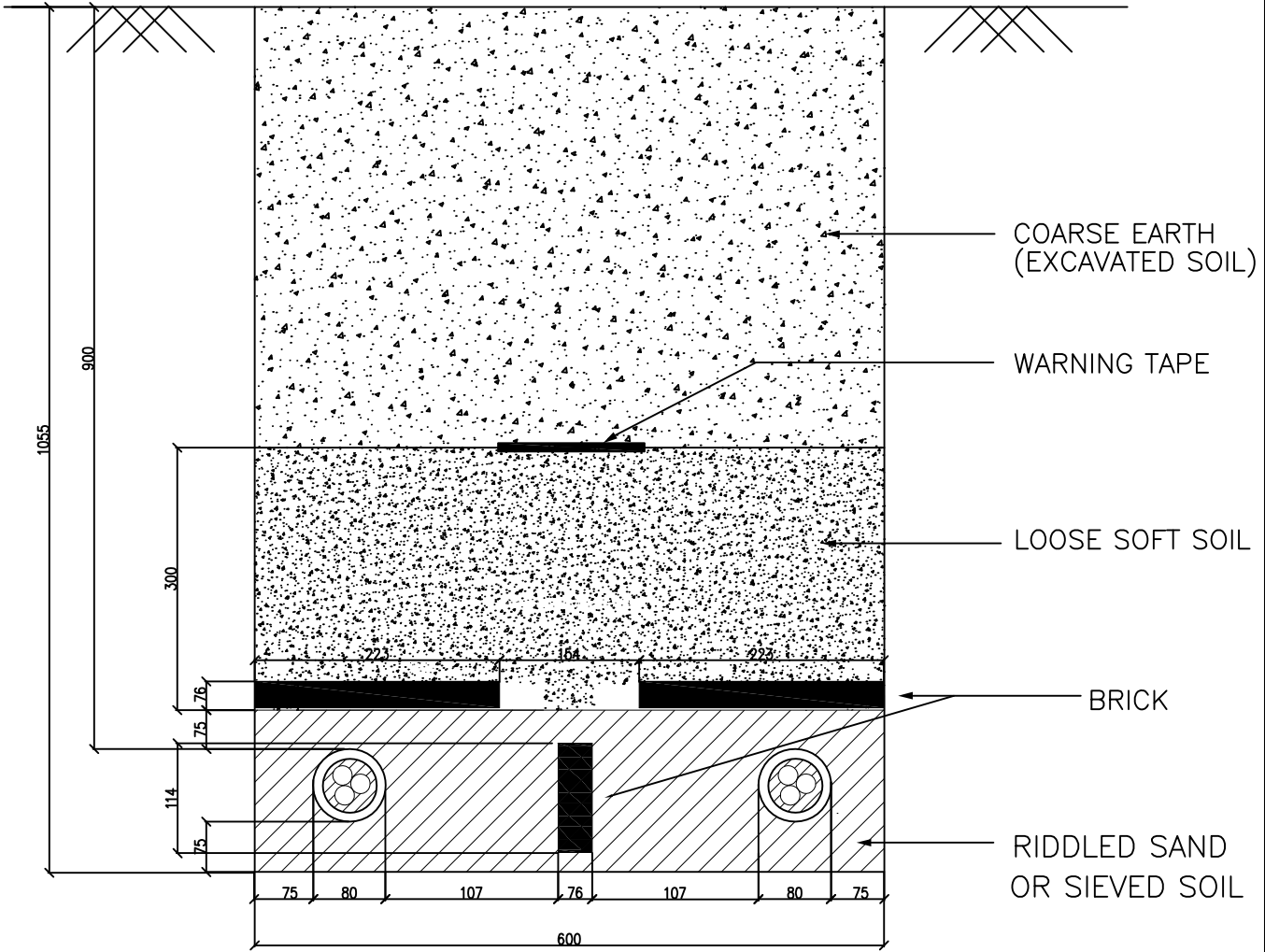

TYPICAL DETAILS FOR 11KV BURIED CABLE FOR TWO CIRCUIT
TYPE - B 1

DRAWN	DS	TITLE:-
CHECKED	SGD	TRENCH DRAWING FOR
APPD.	D.GUHA	3C X 300 mm Sq. or
DATE		3C X 150 mm sq
SCALE		11 KV DOUBLE CIRCUIT
		XLPE CABLE

BSES

REV.
00

DRAWING # 8

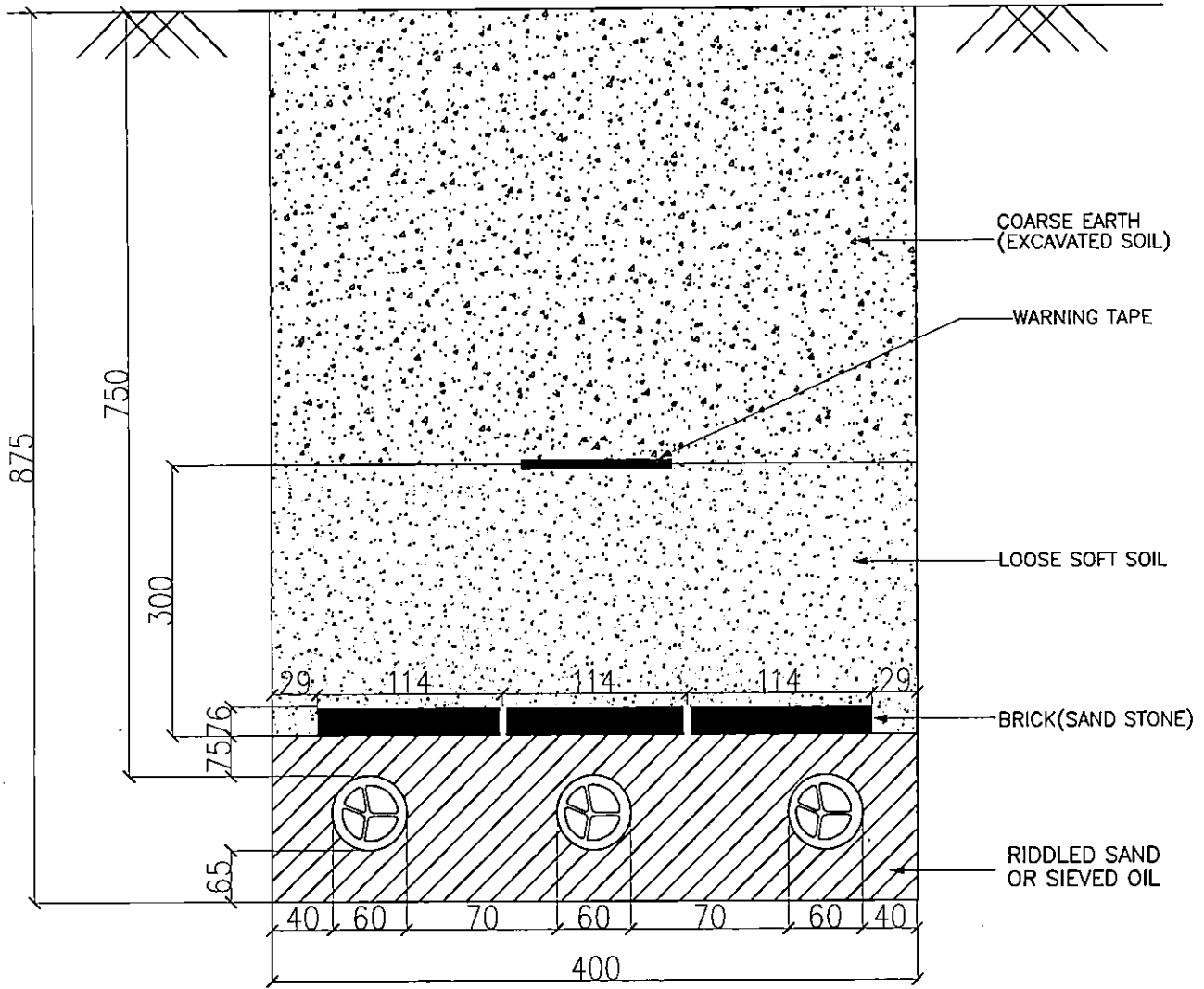

TYPICAL DETAILS FOR 1.1KV BURIED CABLE
TYPE - A 1

DRAWN	DS	TITLE:-
CHECKED	SGD	TRENCH DRAWING FOR
APPD.	D.GUHA	3.5Cx300Sqmm 1.1 KV
DATE		XLPE CABLE
SCALE		

BSES

REV.
00

DRAWING # 8

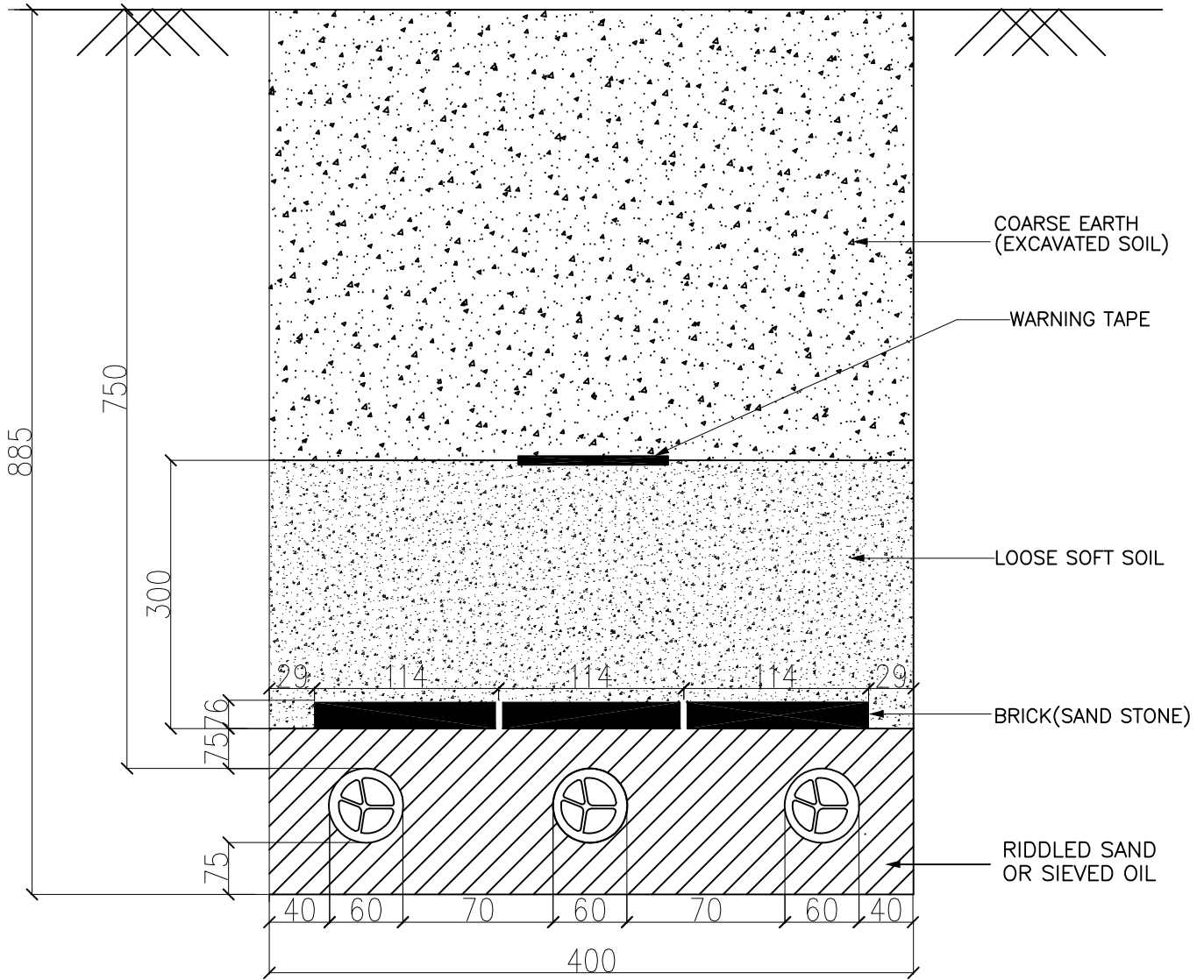

TYPICAL DETAILS FOR 1.1KV BURIED CABLE
TYPE – A 2

DRAWN	DS	TITLE:--	BSES
CHECKED	SGD	TRENCH DRAWING FOR	
APPD.	D.GUHA	3.5Cx300Sqmm 1.1 KV	
DATE		XLPE CABLE	
SCALE			
			REV. 00

DRAWING # 9

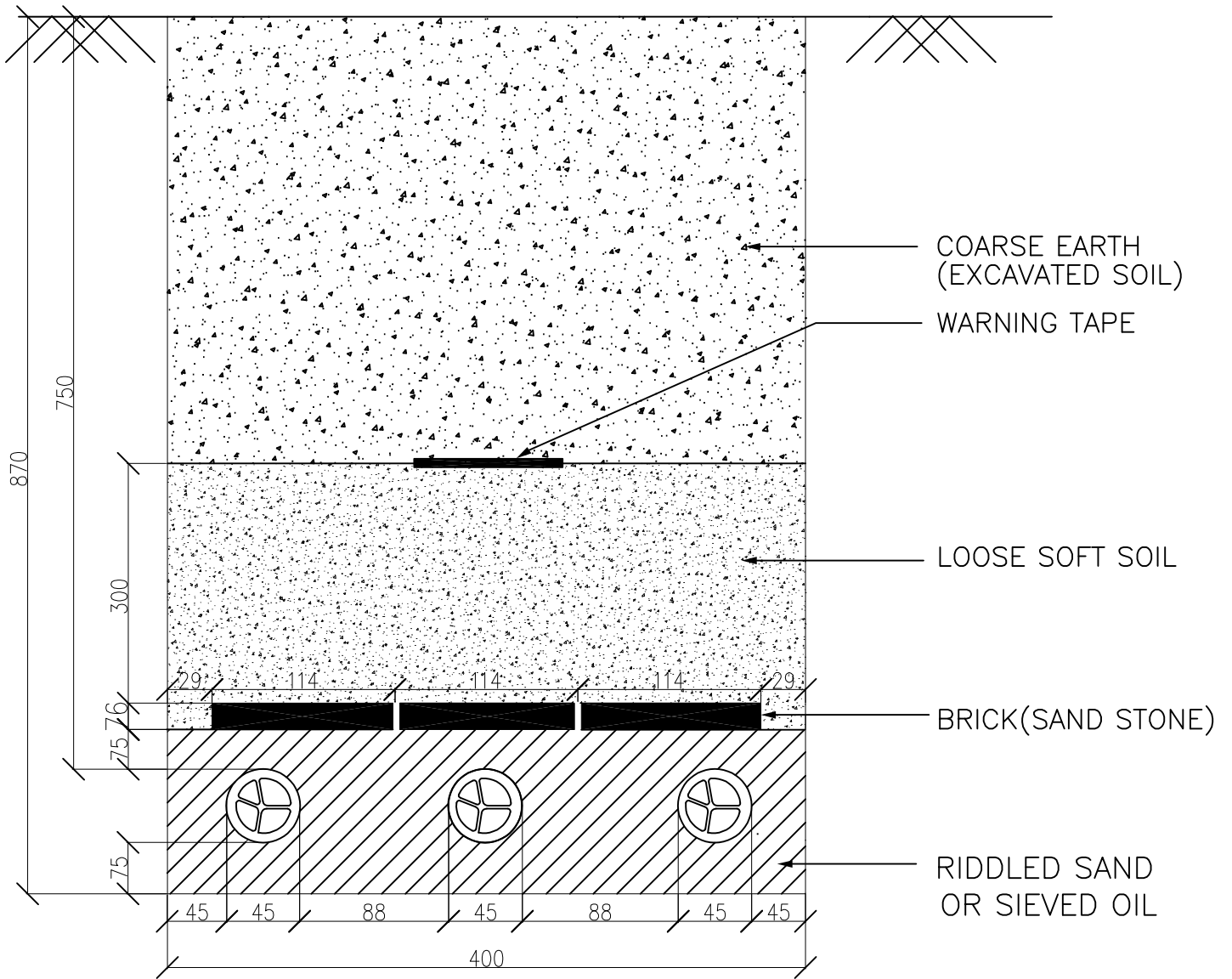

TYPICAL DETAILS FOR 1.1KV BURRIED CABLE
TYPE - A 1

DRAWN	DS	TITLE:-
CHECKED	SGD	TRENCH DRAWING FOR
APPD.	D.GUHA	3.5Cx150Sqmm 1.1 KV
DATE		XLPE CABLE
SCALE		

BSES

REV.
00

DRAWING # 10 A

TRENCH DRAWING FOR 1.1 KV SERVICE CABLE.(Single ckt)

(Common for 4Cx95Sqmm,4Cx50Sqmm , 4Cx25Sqmm , 2Cx25Sqmm , 2Cx10Sqmm XLPE Ar. Cable)

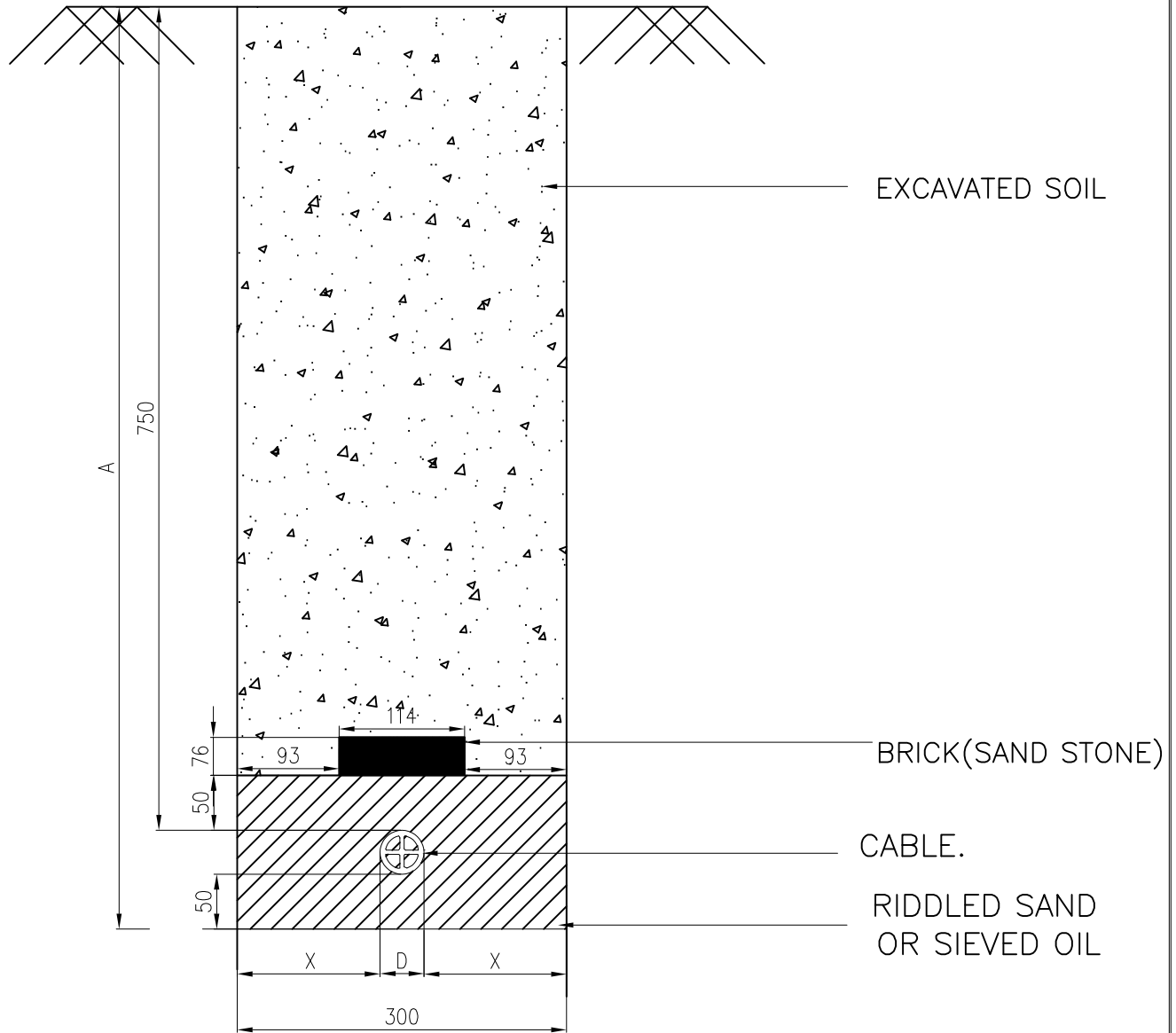

TYPE # D

TABLE No. 1

Sr No	Size of the cable.(outer diameter)	D (mm)	A (Trench depth) (mm)
1.	4Cx95 Sqmm	40 mm	840 mm
2.	4Cx50 Sqmm	35 mm	835 mm
3.	4Cx25 Sqmm	25 mm	825 mm
4.	2Cx25 Sqmm	20 mm	820 mm
5.	2Cx10 Sqmm	17 mm	817 mm

D = Outer diameter of the cable.

$$X = (300 - D) / 2$$

'X' shall be calculated depending on the size and diameter of the cable as provided in Table no.1

DRAWN	DS	TITLE:- TRENCH DRAWING FOR LAYING OF (1.1KV) SERVICE CABLE. (Single Ckt)	BSES
CHECKED	SGD		
APPD.	D.GUHA		
DATE			
SCALE			
			REV. 00

DRAWING # 10 B

TRENCH DRAWING FOR 1.1 KV SERVICE CABLE.(Double ckt)

(Common for 4Cx95Sqmm ,4Cx50Sqmm , 4Cx25Sqmm , 2Cx25Sqmm , 2Cx10Sqmm XLPE Ar. Cable)

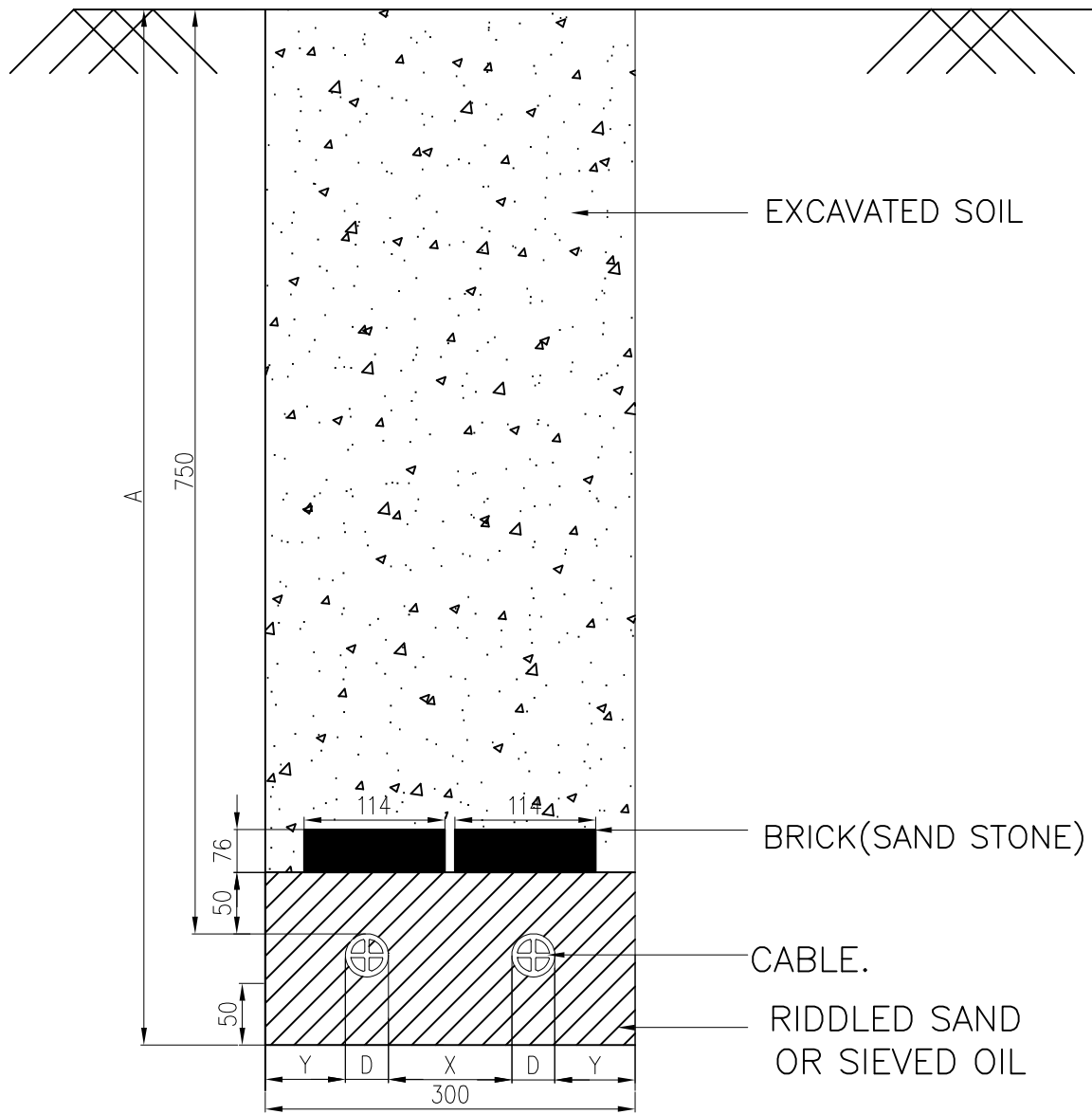

TYPE # D

TABLE No. 1

Sr No	Size of the cable.	D (outer diameter)	A (Trench depth)
1.	4Cx95 Sqmm	40 mm	840 mm
2.	4Cx50 Sqmm	35 mm	835 mm
3.	4Cx25 Sqmm	25 mm	825 mm
4.	2Cx25 Sqmm	20 mm	820 mm
5.	2Cx10 Sqmm	17 mm	817 mm

D = Outer diameter of the cable.

Y = 65

X = (170 - 2 x D)

'X' shall be calculated depending on the size and diameter of the cable as provided in Table no.1

DRAWN	DS	TITLE:-- TRENCH DRAWING FOR LAYING OF (1.1KV) SERVICE CABLE. (Double Ckt)	BSES
CHECKED	SGD		
APPD.	D.GUHA		
DATE			
SCALE			
			REV. 00