

**ANNEXURE- 2**  
**CHECK LIST FOR REGISTRATION FORM**

S.No.	Documents	Required	Submitted
1	Stage-1 approval (NOC) from Discom	YES	
2	Registration form signed by "Registered consumer" on each page with stamp	YES	
3	Detailed SLD of solar plant signed by Registered Consumer and solar plant installer with stamp	YES	
4	<b>Solar PV Module IEC Certificate:</b> IEC 61215/IS14286 (Design Qualification and Type Approval for Crystalline Silicon Terrestrial Photovoltaic (PV) Module)	YES	
	IEC 61730 Part 1 & Part 2 (Photovoltaic (PV) module safety qualification - Part 1: Requirements for construction)	YES	
	IEC 61853: Part 1/ IS 16170: Part 1 (Photovoltaic (PV) module performance testing and energy rating – Irradiance and temperature performance measurements, and power rating)	YES	
	IEC 61701 (For the PV modules to be used in a highly corrosive atmosphere)	YES	
5	<b>Inverter IEC Certificates:</b> IEC 61727 (Photovoltaic (PV) systems - Characteristics of the utility interface)	YES	
	IEC 62116 (Utility-interconnected photovoltaic inverters - Test procedure of islanding prevention measures)	YES	
	IEC 62109-1, IEC 62109-2 (Safety of power converters for use in photovoltaic power systems Safety compliance)	YES	
6	Inverter data Sheet	YES	
7	Solar PV Module data Sheet	YES	
8	Net Metering Connection Agreement on Rs 100 /- non judicial stamp paper, duly attested by Notary public signed by Registered Consumer on each page with stamp	YES	
9	SLD( With check list details)	YES	

**Note : For Non CFA cases - If the installation is completed Kindly refer to Stage-3 relevant Documents also.**

(Additional documents required in case of projects under CFA)

S.No.	DOCUMENTS	REQUIRED	SUBMITTED
10	Covering Letter on Letter head	YES	
11	Copy of CAPEX Agreement/RESCO Agreement (PPA)	YES	
12	Colored site Photographs with Date & Time stamping and geo-Coordinates (before plant installation)	YES	
13	Annexure-D Project Report format	YES	
14	Plant layout	YES	

**Note:** All the above-mentioned documents must be signed by Registered Consumer and solar plant installer with stamp.

## Application for Registration of the Scheme for Renewable Energy System

To,  
The Nodal Officer  
Net Metering- Clean & Sustainable Technology  
Corporate Annex, BSES Yamuna Power Ltd.  
CBD-III Grid Karkar Dooma,  
Opp Unity One mall, Delhi -110032



I intend to register for the scheme for Renewable Energy System, in compliance of Delhi Electricity Regulatory Commission (Net Metering for Renewable Energy) Regulations, 2014.

1	Name of Registered Consumer			
2	Address of Registered Consumer			
3	CA No		Sanctioned load as per latest Electricity Bill	
4	Net-metering application no	NM-	Supply voltage (230, 415, 11, 33, 66 KV)	
5	Mobile No of consumer		Mobile No of Installer	
6	E-Mail ID of consumer (In Capital letters)			
7	E-Mail ID of installer (In Capital letters)			
8	Renewable Energy Source type	(solar / wind / other)	Capacity of Renewable Energy System	
9	Name of solar plant Installer		Proposed date of completion of the installation	

I ..... (Name of Consumer) undertake that ownership of the roof/land where solar PV system is installed is with me. I shall comply with the terms and condition of Model Connection Agreement. I agree to pay the Registration charges (details as provided below) as stipulated under Delhi Electricity Regulatory Commission (Net Metering for Renewable Energy) Regulations, 2014 once this application for registration is approved. Also, I agree to pay registration charges & all other applicable charges raised by the DISCOM through my electricity bill.

Sr . No.	Capacity (KWp)	Charges (Rs)	Please tick any one as per your plant capacity
1	1 to ≤ 10	1000/-	
2	>10 to ≤ 50	3000/-	
3	> 50 to ≤ 100	6000/-	
4	>100 to ≤ 300	9000/-	
5	>300 to ≤ 500	12000/-	
6	>500	15000/-	

**Enclosure: Documents as per "Checklist of Registration form" (annexure -II)**

Place:

Date:

**Signature of Registered Consumer**

### For Office Use Only

<b>Registration Number:</b>		<b>Registration Date:</b>	
-----------------------------	--	---------------------------	--

For any query call us on 011-41247031 , 41247068 or E-Mail us on [netmetering.bypl@relianceada.com](mailto:netmetering.bypl@relianceada.com)

Stamp Paper Certificate No:.....

**(On Rs.100/- non judicial stamp paper. duly attested by Notary public)**  
**Net Metering Model Connection Agreement For Renewable Energy**

This Agreement is made and entered into at New Delhi on date \_\_\_\_\_ between the Registered consumer name \_\_\_\_\_ CA no: \_\_\_\_\_ & applied solar capacity \_\_\_\_\_ (in KW) residing at \_\_\_\_\_ as first party and **BSES Yamuna Power Ltd.** (herein after called as Discom) and having its registered office at Shakti Kiran Bldg, Karkardooma Delhi, 110032 as second party of the agreement.

**1. Eligibility**

1.1 Eligible consumer is required to be aware, in advance, of the standards and conditions his system has to meet for being integrated into grid/distribution system.

1.2 Eligible consumer agrees that connection of Photovoltaic system to Discom's distribution system shall be bound by requirements of state Distribution Code and/or Discom's conditions of service and Delhi Electricity Regulatory Commission (Net Metering for Renewable Energy) Regulations, 2014. The grid shall continue to perform with specified reliability, security and quality as per the Central Electricity Authority (Grid Standard) Regulations 2010 as amended from time to time.

**2. Technical and Interconnection Requirements**

2.1 Eligible consumer agrees that he has installed or will install, prior to connection of Photovoltaic system to Discom's distribution system, an isolation device (both automatic and inbuilt within inverter and external manual relays) and agrees for the Discom to have access to and operation of this, if required, for repair and maintenance of the distribution system.

2.2 Eligible consumer agrees that in case of a power outage on Discom's system, photovoltaic system will shut down, unless special transfer and isolating capabilities have been installed on photovoltaic system.

2.3 Technical specification of net meter and renewable energy meter should be in compliance to Discom.

2.4 All the equipment connected to distribution system must be complaint with relevant International (IEEE/IEC) or Indian standards (BIS) and installations of electrical equipment must comply with Indian Electricity rules, 1956 and Central Electricity.

2.5 Eligible consumer agrees that Discom will specify the interface/inter-connection point and metering point.

2.6 Eligible consumer agrees to adhere to following power quality measures as per International or Indian standards and/or other such measures provided by Commission / Discom.

A. Harmonic current: Harmonic current injections from a generating station shall not exceed the limits specified in IEEE 519.

B. Synchronization: Photovoltaic system must be equipped with a grid frequency synchronization device.

C. Voltage: The voltage-operating window should minimize nuisance tripping and should be under operating range of 80% to 110% of the nominal connected voltage. Beyond a clearing time of 2 seconds, the Photovoltaic system must isolate itself from the grid.

D. Flicker: Operation of Photovoltaic system shouldn't cause voltage flicker in excess of the limits stated in the relevant sections of IEC standards or other equivalent Indian standards, if any.

E. Frequency: When the Distribution system frequency deviates outside the specified conditions (50.5 Hz on upper side and 47.5 Hz on lower side), the Photovoltaic system shouldn't energize the grid and should shift to island mode.

F. DC Injection: Photovoltaic system should not inject DC power more than 0.5% of full rated output at the interconnection point or 1% of rated inverter output current into distribution system under any operating conditions.

G. Power Factor: While the output of the inverter is greater than 50%, a lagging power factor of greater than 0.9 should operate.

H. Islanding and Disconnection: The Photovoltaic system in the event of voltage or frequency variations must island/disconnect itself within IEC standard on stipulated Period.

I. Overload and Overheat: The inverter should have the facility to automatically switch off in case of overload or overheating and should restart when normal conditions are restored.

J. Paralleling device: Paralleling device of Photovoltaic system shall be capable of withstanding 220% of the nominal voltage at the interconnection point.

2.7 Eligible consumer agrees to furnish all the data such as voltage, frequency, and breaker, isolator position in his system, as and when required by the Discom. He may also try to provide facilities for online transfer of the real time operational data.

### **3. Safety**

3.1 Eligible consumer shall comply with the Central Electricity Authority (Measures Relating to Safety and Electricity Supply) Regulations 2010.

3.2 Eligible consumer agrees that the design, installation, maintenance and operation of the photovoltaic system are performed in a manner conducive to the safety of the photovoltaic system as well as the Discom's distribution system.

3.3 Due to Discom's obligation to maintain a safe and reliable distribution system, eligible consumer agrees that if it is determined by Discom that eligible consumer's photovoltaic system either causes damage to and/or produces adverse effects affecting other distribution systems' consumers or Discom's assets, eligible consumer will have to disconnect photovoltaic system immediately from the distribution system upon direction from the Discom and correct the problem at his own expense prior to a reconnection.

#### **4. Clearances and Approvals**

4.1 The eligible consumer agrees to attain all the necessary approvals and clearances (environmental and grid connected related) before connecting the photovoltaic system to the distribution system.

#### **5. Access and Disconnection**

5.1 Discom shall have access to metering equipment and disconnecting means of photovoltaic system, both automatic and manual, at all times.

5.2 In emergency or outage situation, where there is no access to a disconnecting means, both automatic and manual, such as a switch or breaker, Discom may disconnect service to the premise.

#### **6. Liabilities**

6.1 Eligible consumer and Discom will indemnify each other for damages or adverse effects from either party's negligence or intentional misconduct in the connection and operation of photovoltaic system or Discom's distribution system.

6.2 Discom and eligible consumer will not be liable to each other for any loss of profits or revenues, business interruption losses, loss of contract or loss of goodwill, or for indirect, consequential, incidental or special damages, including, but not limited to, punitive or exemplary damages, whether any of the said liability, loss or damages arise in contract, or otherwise.

6.3 Discom shall not be liable for delivery or realization by eligible consumer for any fiscal or other incentive provided by the central government.

#### **7. Commercial Settlement**

7.1 All the commercial settlement under this agreement shall follow the Net metering regulations of Delhi Electricity Regulatory Commission (Net Metering for Renewable Energy) Regulations, 2014.

#### **8. Conditions for System Connectivity**

8.1 The parties shall abide by the Central Electricity Regulatory Commission Regulations in respect of procedure of grant of Connectivity. The consumer shall submit the following documents to discom for the grant of connectivity:

- ✓ Synchronization Circuit Details
- ✓ Safety Report
- ✓ Protection Circuit Details
- ✓ Test Certificates of System
- ✓ Schematic diagram of Renewable Energy system

## 9. Connection Costs

9.1 The eligible consumer shall bear all costs related to setting up of photo-voltaic system including metering and interconnection costs as per estimate by BYPL. The eligible consumer agrees to pay the actual cost of modifications and upgrades to the distribution facilities required to connect photo-voltaic system in case it is required.

9.2 Cost for interconnection equipment including the isolators, meters etc. are also to be borne by the eligible consumer.

## 10. Termination

10.1 The eligible consumer can terminate agreement at any time by providing Discom with 90 days prior notice.

10.2 Discom has the right to terminate Agreement on 30 days prior written notice, If eligible consumer breaches a term of this Agreement and does not remedy the breach within 30 days of receiving written notice from Discom of the breach.

10.3 Eligible consumer agrees that upon termination of this Agreement, he must disconnect the photovoltaic system from Discom's distribution system in a timely manner and to Discom's satisfaction.

In the witness, where of Mr. \_\_\_\_\_ For and on behalf of (Registered consumer) and Mr \_\_\_\_\_ for and on behalf of **BSES Yamuna Power Limited** agree to this agreement.

**Date :**

\_\_\_\_\_  
Name & Signature of  
Registered Consumer

\_\_\_\_\_  
Signature of Head Net Metering  
**BSES Yamuna Power Limited**

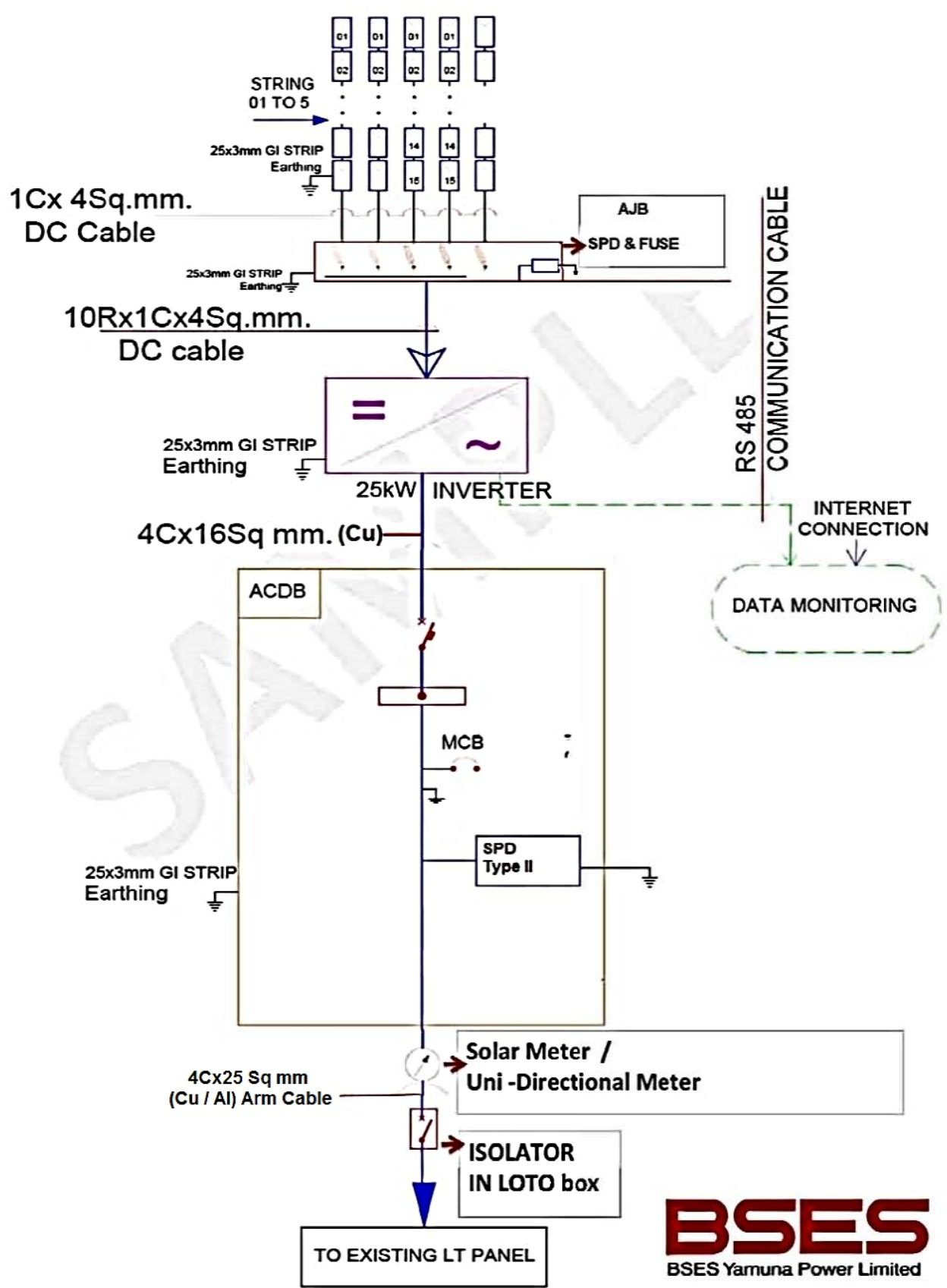
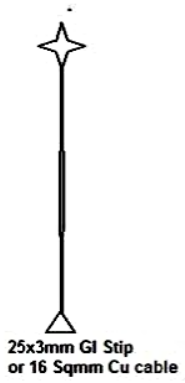

# SAMPLE SLD

**FOR ILLUSTRATION PURPOSE ONLY**

**Check List I: Single Line Diagram (SLD)**

S.No	PARAMETERS	REMARKS
1	Array Configuration (as per MPPT Range)- No. of Module per string and no of strings	No of Modules per string- No of Strings
2	Module Sizing	
2.a	Rating of Module	
2.b	No of Modules	
3	Inverter Sizing	
3.a	Rating of Inverter	
3.b	No of Inverter	
3.c	Inverter Type (1-Phase/3-Phase)	
4	AJB / DCDB Circuit Diagram	
4.a	SPD's	
4.b	Fuses	
5	ACDB Circuit Diagram	
5.a	SPD's	
5.b	MCB/MCCB's	
6	DC Cable Sizing marking	
6.a	DC Cable size, type (CU) and length from Module to Inverter	
7	AC Cable Sizing Marking	
7.a	AC Cable size, type (CU) and length from Inverter to ACDB	
7.b	AC Cable size, type Arm(CU/AL)& length from ACDB to LT panel	
8	Manual Isolation Switch (LOTO) at Solar Meter Output	
9	Lightning Arrestor (Count & Type)	
10	Earth Pits	
10.a	DC Earth Pit (Array Structure & AJB)	
10.b	Conductor/Strip size & type (CU/AL/GI)	
10.c	AC Earth Pit (Inverter, ACDB & LT Panel)	
10.d	Conductor/Strip size & type (CU/AL/GI)	
10.e	LA earth Pit	
10.f	Conductor/Strip size & type (CU/AL/GI)	
11	Solar Meter	
12	Net Meter	
13	Data Logger	
14	LT Panel	
15	HT panel, CB, Transformer with Rating (if applicable)	
16	Plant Capacity Rating (DC)	
17	Plant Capacity Rating (AC)	

**Consumer Signature**

**Installer Signature**



## Layout for the Interconnection of Rooftop Solar Plant

